



SERVICE MANUAL

**FOR
GENERAL 5 STAR ST MOPED
with
SACHS 505 1A ENGINE**

**GENERAL MOPED CO., INC.
PERMA-LINED BLDG
50 OAK STREET
EAST RUTHERFORD, N.J. 07073
TEL: (212) 564-3876**

**ALL PARTS ORDERS SHOULD BE FORWARDED TO:
GENERAL MOPED CO., INC.
450 SEVENTH AVENUE
NEW YORK, N.Y. 10001
U. S. A.**

253
5107
844



moped

CONTENTS

Technical Data.....	1
Part: List Frame Group.....	2-33
Front Wheel Assembly.....	2- 3
Rear Wheel Assembly.....	4- 5
Front Fork Assembly.....	6- 7
Rear Shock & Swing Arm.....	8- 9
Handle Bar & Cable.....	10-11
Frame Assembly.....	12-13
Fuel Tank & Seat.....	14-15
Front Fender & Rear Fender.....	16-17
Speedometer Assembly.....	18-19
Chain Cover.....	20-21
Crank & Pedal Assembly.....	22-23
Muffler Assembly.....	24-25
Turn Signal Assembly.....	26-27
Head Light Assembly.....	28-29
Tail Light Assembly.....	30-31
Wire Harness & Electricity.....	32-33
Part List Engine Group.....	34-47
Crank Case, Crank Shaft, Piston, Cylinder, Decompressor, Intake Pipe.....	34-35
Gear Box.....	36-37
Clutch.....	38-39
Magneto-Generator.....	40-41
Pedal Shaft.....	42-43
Carburetor.....	44-45
Intake Silencer.....	46-47
Repair Tools & Mounting Jig.....	48
Owner Tool Kit & Repair Tools.....	49
Dismantling The Engine.....	50-53
Working On Individual Parts.....	53-57
Rebuilding The Engine.....	58-63
Operations After Engine Overhaul.....	64-65

Tightening Torsion For All Nuts & Bolts.....	66
Assembly Instructions.....	67
Engine Starting & Preparation Instructions For Riding...	68
Adjustment For Drive Chain.....	69
Brakes Adjusting.....	69
Maintenance Of Battery.....	70
Essential Maintenance.....	71
Troubleshooting.....	72-73
Electrical Wiring.....	74

TECHNICAL DATA

Frame	: Heavy-Gauge Sturdy Tubular Steel Frame
Front Suspension	: Heavy Duty Telescopic Hydraulic Shock Absorber
Rear Suspension	: Swing Arm & Telescopic Hydraulic Shock Absorber
Brakes	: Dual Drum Brakes/Hand & Foot Brakes
Tire, Front & Rear	: 17" x 2.25"
Wheel Base	: 44-1/8"
Dimension	: 67 $\frac{3}{4}$ "(L)x26 $\frac{1}{2}$ "(W)x40"(H)
Fuel Tank	: 1.1 Gallon Capacity
Fuel Consumption	: 170 Miles/Gallon
Net Weight	: 54kg 119 LBS.
Engine	: SACHS 505/1B, 2-Stroke Air-Cooled Single Cylinder ("505/1A is also available)
Engine Starting	: Pedal System
Engine Output	: 1.1 kw (1.5 PS) at 4000 1/min.
Compression Rate	: 8:1
Exhaust	: 47cc
Ignition	: BOSCH Magneto-Generator, Mainlight 6V22W Taillight 6V5W
Spark Plug	: BOSCH W 175 T 1(with SAE connecting nut)
Transmission	: Automatic Clutch
Maximum Speed	: 20 MPH/1B, 25 MPH/1A
Maximum Steeping	: 22°30'
Head Light	: SAE Certified
Tail Light	: SAE Certified
Other Accessories	: SAE Certified Front & Rear Turn Signal Assembly (Left & right), Rear View Mirror, etc.

FRONT WHEEL ASSEMBLY

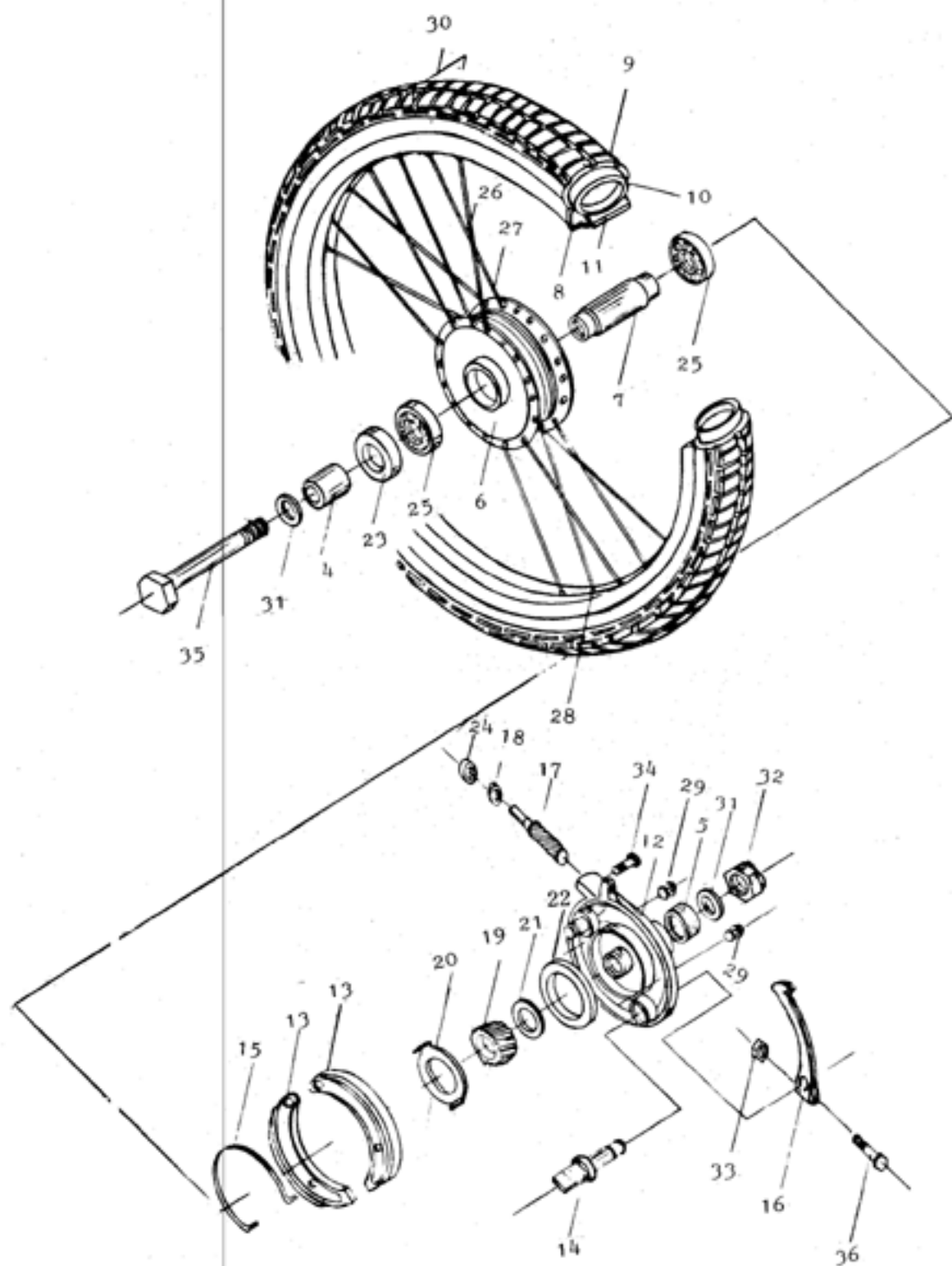

TABLE-1

FRONT WHEEL ASSEMBLY

REF NO.	PART NO.	QUANTITY	DESCRIPTION
1	1150-5099	1	HUB ASSEMBLY (6. 7. 23. 25)
2	1150-5098	1	BACKING PLATE ASSEMBLY (12-22. 24. 29. 33. 34. 36)
3	1150-5097	1	HUB, RIM, SPOKE ASSEMBLY (1. 8. 26. 27. 28)
4	1150-5096	1	SPACER L/H
5	1150-5095	1	SPACER R/H
6	1150-5094	1	HUB
7	1150-5093	1	COLLAR
8	1150-5092	1	RIM 2.25x17
9	1150-5091	1	TIRE 2.25x17
10	1150-5090	1	TUBE 2.25x17
11	1150-5089	1	RIM STRAP 2.25x17
12	1150-5088	1	PANEL BRAKE
13	1150-5087	2	BRAKE SHOE
14	1150-5086	1	BRAKE CAM
15	1150-5085	1	SPRING BRAKE SHOE
16	1150-5084	1	BRAKE ARM
17	1150-5083	1	PINION SPEEDOMETER
18	1150-5082	1	WASHER SPEEDOMETER PINION
19	1150-5081	1	GEAR SPEEDOMETER
20	1150-5080	1	RECEIVER SPEEDOMETER
21	1150-5079	1	WASHER, GEAR BOX
22	1150-5078	1	OIL SEAL, 39x47x5
23	1150-5077	1	OIL SEAL, 17x32x6
24	1150-5076	1	OIL SEAL, 4.5x11x3.5
25	1150-5075	2	BEARING 6201
26	1150-5074	16	OUTER SPOKE #12x176
27	1150-5073	16	INNER SPOKE #12x176
28	1150-5072	3	NIPPLE
29	1150-5071	2	RUBBER PLUG
30	1150-5000	1	FRONT WHEEL ASSEMBLY (WITHOUT 1. 2. 3)
31	6210-0110	2	PLAIN WASHER 10mm
32	6180-0110	1	LOOK NUT 10mm
33	6160-0105	1	NUT 5mm
34	6130-4006	1	SCREW 4x6
35	6111-0145	1	AXLE 10x145
36	6110-5022	1	BOLT 5x22

REAR WHEEL ASSEMBLY

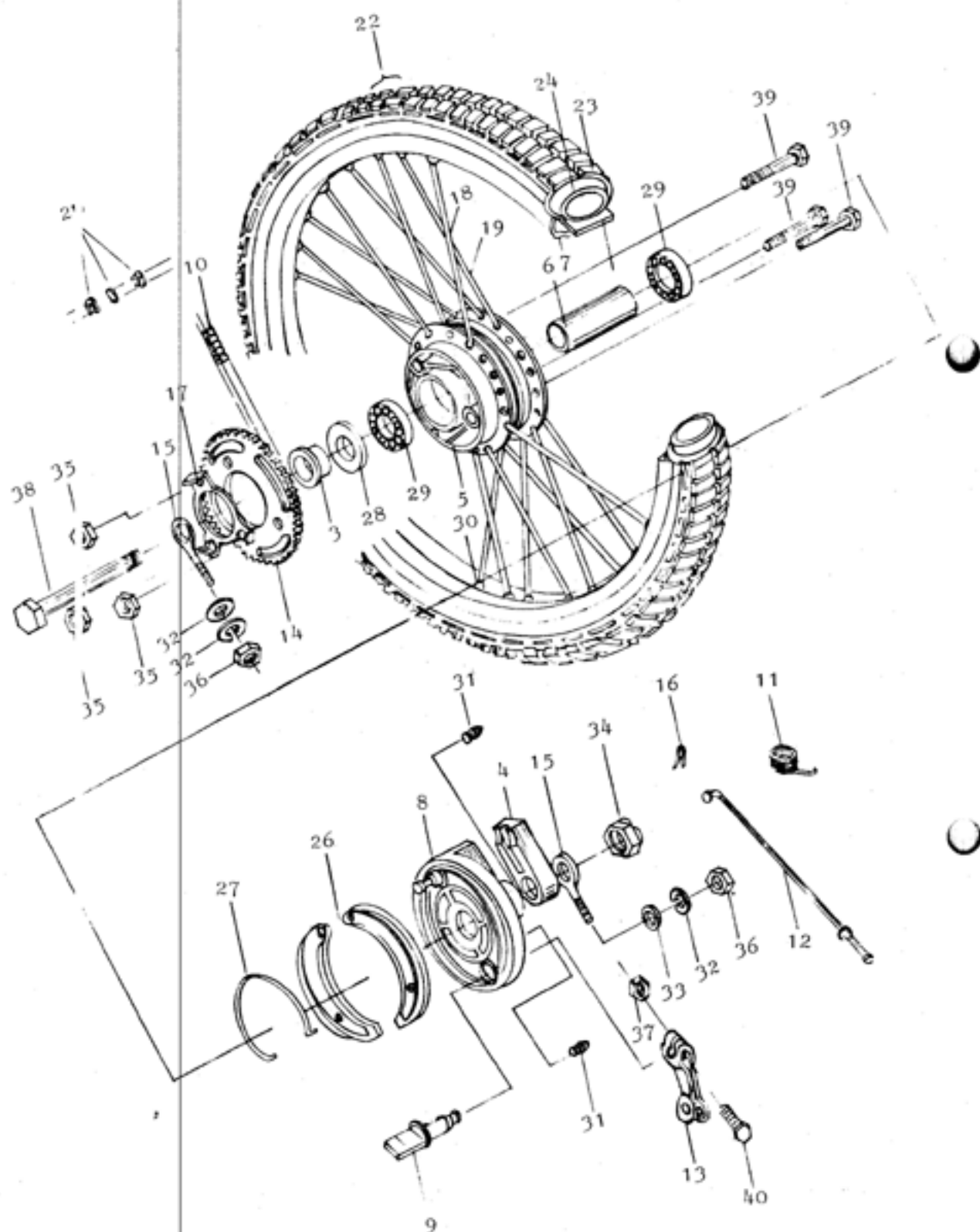

TABLE-2

REAR WHEEL ASSEMBLY

REF NO.	PART NO.	QUANTITY	DESCRIPTION
1	1150-5499	1	HUB ASSEMBLY (5. 6. 28. 29)
2	2150-5498	1	BACKING PLATE ASSEMBLY (8. 9. 13. 26. 27. 31. 37. 40)
3	1150-5497	1	COLLAR L/H
4	1150-5496	1	TENSION BRACKET
5	1150-5495	1	HUB
6	1150-5494	1	COLLAR
7	1150-5492	1	RIM 2.25x17
8	1150-5490	1	PANEL BRAKE
9	1150-5489	1	BRAKE CAM
10	2150-5487	1	CHAIN #415x10 ^h
11	2150-5486	1	SPRING (REAR BRAKE LEVER)
12	2150-5485	1	BRAKE ROD
13	2150-5484	1	BRAKE ARM
14	2150-5482	1	SPROCKET FINAL DRIVEN 40T
15	1150-5481	2	ADJUSTER DRIVE CHAIN
16	2150-5479	1	SNAP PIN
17	1150-5478	1	TONGUED WASHER
18	1150-5470	18	OUTER SPOKE #12x171
19	1150-5469	18	INNER SPOKE #12x171
20	1150-5468	1	JOINT, DRIVEN CHAIN
21	1150-5467	1	HUB, RIM, SPOKE, ASSEMBLY(1. 7. 18. 19. 30)
22	2150-5400	1	REAR WHEEL ASSEMBLY (1. 2. 10. 20. 21)
23	1150-5091	1	TIRE 2.25x17
24	1150-5090	1	TUBE 2.25x17
25	1150-5089	1	RIM STRAP 2.25x17
26	1150-5087	2	BRAKE SHOE
27	1150-5085	1	SPRING, BRAKE SHOE
28	1150-5077	1	OIL SEAL 17x32x6
29	1150-5075	2	BEARING 6201
30	1150-5072	36	NIPPLE
31	1150-5071	2	RUBBER PLUG
32	6220-1106	2	SPRING WASHER 6mm
33	6210-0106	2	PLAIN WASHER 6mm
34	6180-0112	1	LOCK NUT 12mm
35	6160-0108	3	NUT 8mm
36	6160-0106	2	NUT 6mm
37	6160-0105	1	NUT 5mm
38	6111-2172	1	AXLE 12x172
39	6110-8034	3	BOLT 8x34
40	6110-5022	1	BOLT 5x22

FRONT FORK ASSEMBLY

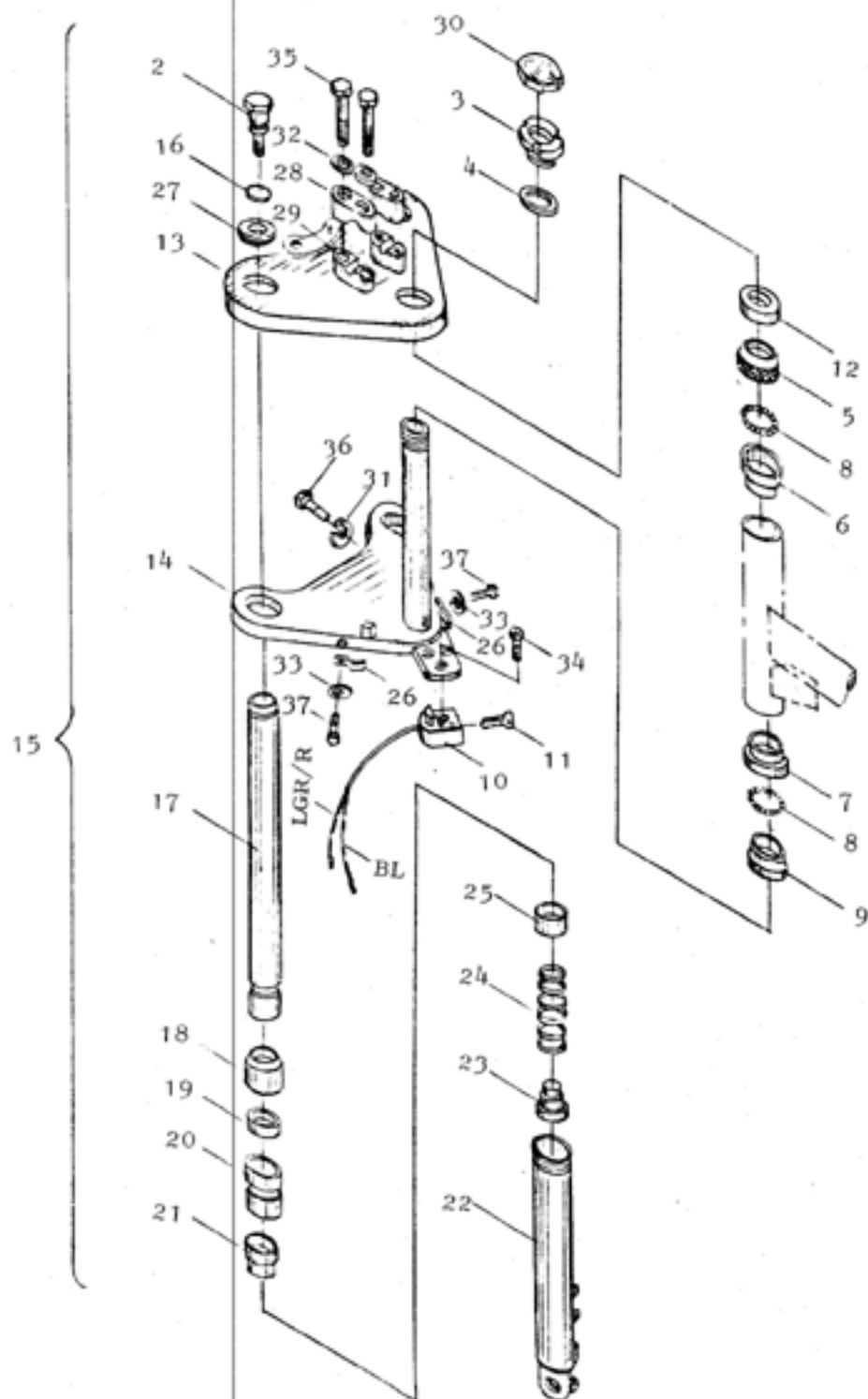

TABLE-3

FRONT FORK ASSEMBLY

REF NO.	PART NO.	QUANTITY	DESCRIPTION
1	150-5899	1	FRONT FORK ASSEMBLY (WITHOUT 5-11. 28. 29. 32. 34. 35)
2	150-5898	2	BOLT, FRONT FORK
3	150-5895	1	NUT, STEERING HEAD STEM
4	150-5894	1	PLAIN WASHER
5	150-5893	1	RACE, STEERING TOP CONE
6	150-5892	1	STEERING BALL TOP RACE
7	150-5891	1	STEERING BALL BOTTOM RACE
8	150-5890	46	STEERING BALL 3/16"
9	150-5889	1	STEERING CONE BOTTOM RACE
10	150-5888	1	LOCK
11	150-5887	2	KEY (SPECIFY CODE NUMBER)
12	150-5886	1	SPACER
13	150-5885	1	TOP CROWN
14	150-5884	1	BOTTOM CROWN
15	150-5883	1	LEG, ASSEMBLY L/H
	150-5882	1	LEG, ASSEMBLY R/H
16	150-5881	2	OIL RING
17	150-5880	2	INNER TUBE
18	150-5879	2	DUST COVER
19	150-5878	2	OIL SEAL
20	150-5877	2	FORK NUT
21	150-5876	2	GUIDE, FRONT FORK TUBE
22	150-5875	1	OUTER TUBE L/H
	150-5868	1	OUTER TUBE R/H
23	150-5874	2	STOPPER FRONT FORK SPRING
24	150-5873	2	SPRING
25	150-5872	2	SET FRONT FORK TUBE
26	150-5871	2	HOOK
27	150-5869	2	WASHER
28	150-5867	2	UPPER HOLDER, HANDLE BAR
29	150-5866	2	UNDER HOLDER, HANDLE BAR
30	150-5860	1	CAP NUT, STEERING STEM
31	€220-1108	2	SPRING WASHER 8mm
32	€210-0108	4	PLAIN WASHER 8mm
33	€210-0106	2	PLAIN WASHER 6mm
34	€140-6010	2	SCREW 6x10
35	€110-8055	4	BOLT 8x55
36	€110-8030	2	BOLT 8x30
37	€110-6010	2	BOLT 6x10

REAR SHOCK & SWING ARM

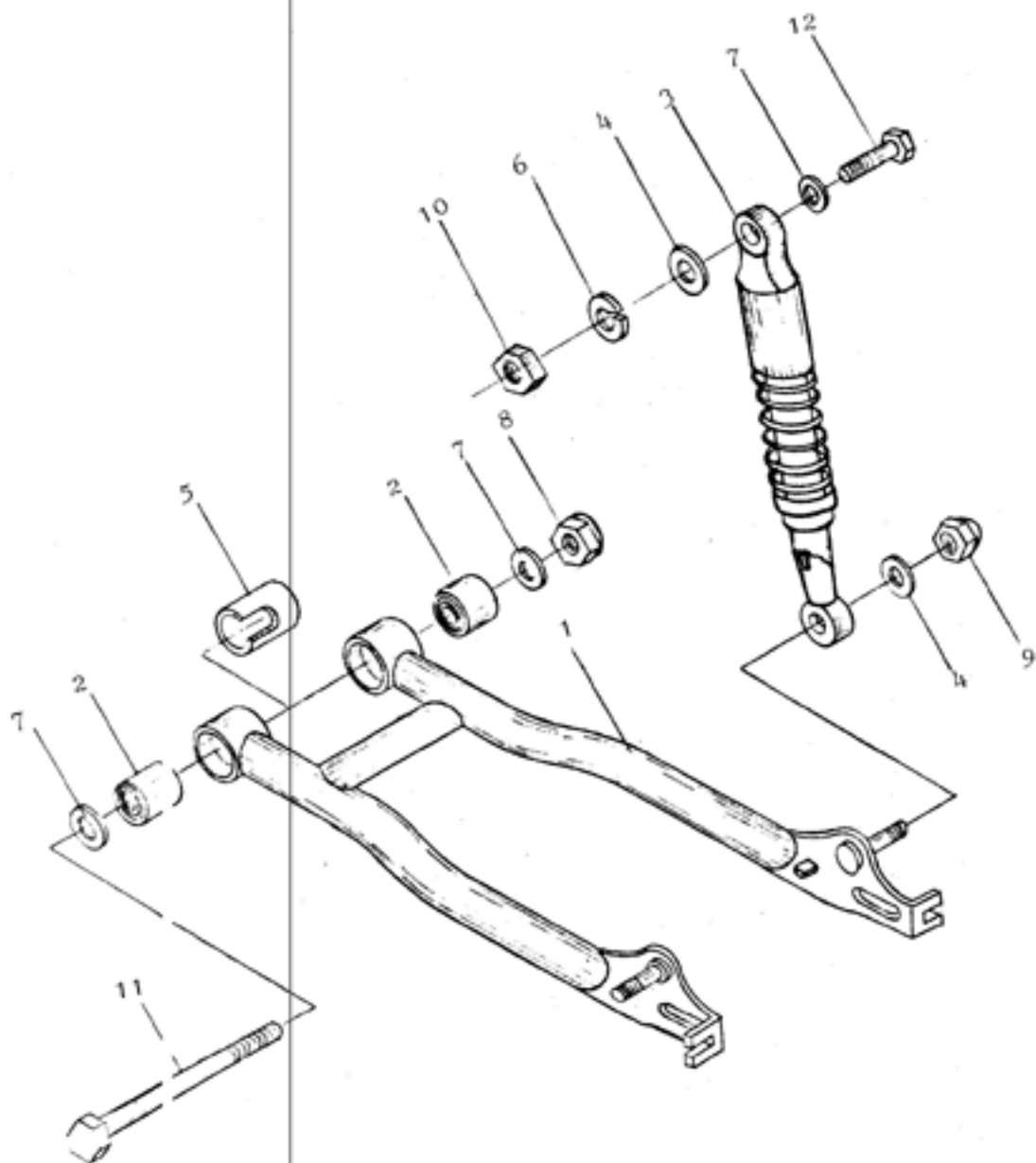

TABLE-1

REAR SHOCK & SWING ARM

REF NO.	PART NO.	QUANTITY	DESCRIPTION
1	1150-6099	1	SWING ARM
2	1150-6098	2	BUSH
3	2150-6097	2	SHOCK ASSEMBLY
4	1150-6096	4	PLAIN WASHER
5	2150-6646	1	CHAIN PROTECTING RING
6	6220-1110	2	SPRING WASHER 10mm
7	6210-0110	4	PLAIN WASHER 10mm
8	6180-0110	1	LOCK NUT 10mm
9	6170-0110	2	CAP NUT 10mm
10	6160-0110	2	NUT 10mm
11	6111-0160	1	AXLE 10x160
12	6111-0040	2	BOLT 10x40

TABLE-5

HANDLE BAR & CABLE

REF. NO.	PART. NO.	QUANTITY	DESCRIPTION
1	3150-6299	1	HANDLE BAR
2	4150-6298	1	SWITCH L/H
3	4150-6297	1	SWITCH R/H
4	2150-6296	1	CABLE, THROTTLE
5	1150-6294	1	CABLE, FRONT BRAKE
6	4150-6293	1	CABLE, CLUTCH
7	3150-6292	1	GRIP L/H
8	3150-6291	1	GRIP R/H
9	3150-6290	1	THROTTLE PIPE
10	4150-6287	1	LEVER L/H (CLUTCH)
11	3150-6286	1	LEVER R/H (FRONT BRAKE)
12	4150-6284	1	CABLE CHOKE
13	1150-6283	1	BACK VIEW MIRROR L/H
14	4150-6282	1	HANDLE LEVER ASSEMBLY L/H (2.10.16.18.21.26.27.28.29.34x3.35.36.37x2.)
15	4150-6281	1	HANDLE LEVER ASSEMBLY R/H (3.11.16.17.18.22.23.24.25.30.31.32.33.34x3.35.36.37x3.)
16	3150-6280	2	BUSH
17	1150-6279	1	ADJUSTER BOLT
18	1150-6278	2	ADJUSTER NUT
19	2150-6276	1	CABLE HEAD
20	1150-6275	4	TIE STRAP
21	2150-6274	1	ADJUSTER BOLT
22	4150-6272	1	SPRING WASHER
23	4150-6271	1	PLAIN WASHER
24	4150-6270	1	LEVER, CHOKE
25	4150-6269	1	BRACKET, CHOKE LEVER
26	4150-9089	1	DECAL START
27	3150-9088	1	DECAL HORN
28	3150-9087	1	DECAL OFF ON
29	3150-9086	1	DECAL LIGHTS
30	4150-9085	1	DECAL CHOKE
31	3150-9084	1	DECAL STOP
32	3150-9083	1	DECAL ENGINE STOP
33	3150-9082	1	DECAL L. TURN. R.
34	6220-1105	6	SPRING WASHER 5mm
35	6160-0105	2	NUT 5mm
36	6130-5030	2	SCREW 5x30
37	6130-5025	5	SCREW 5x25

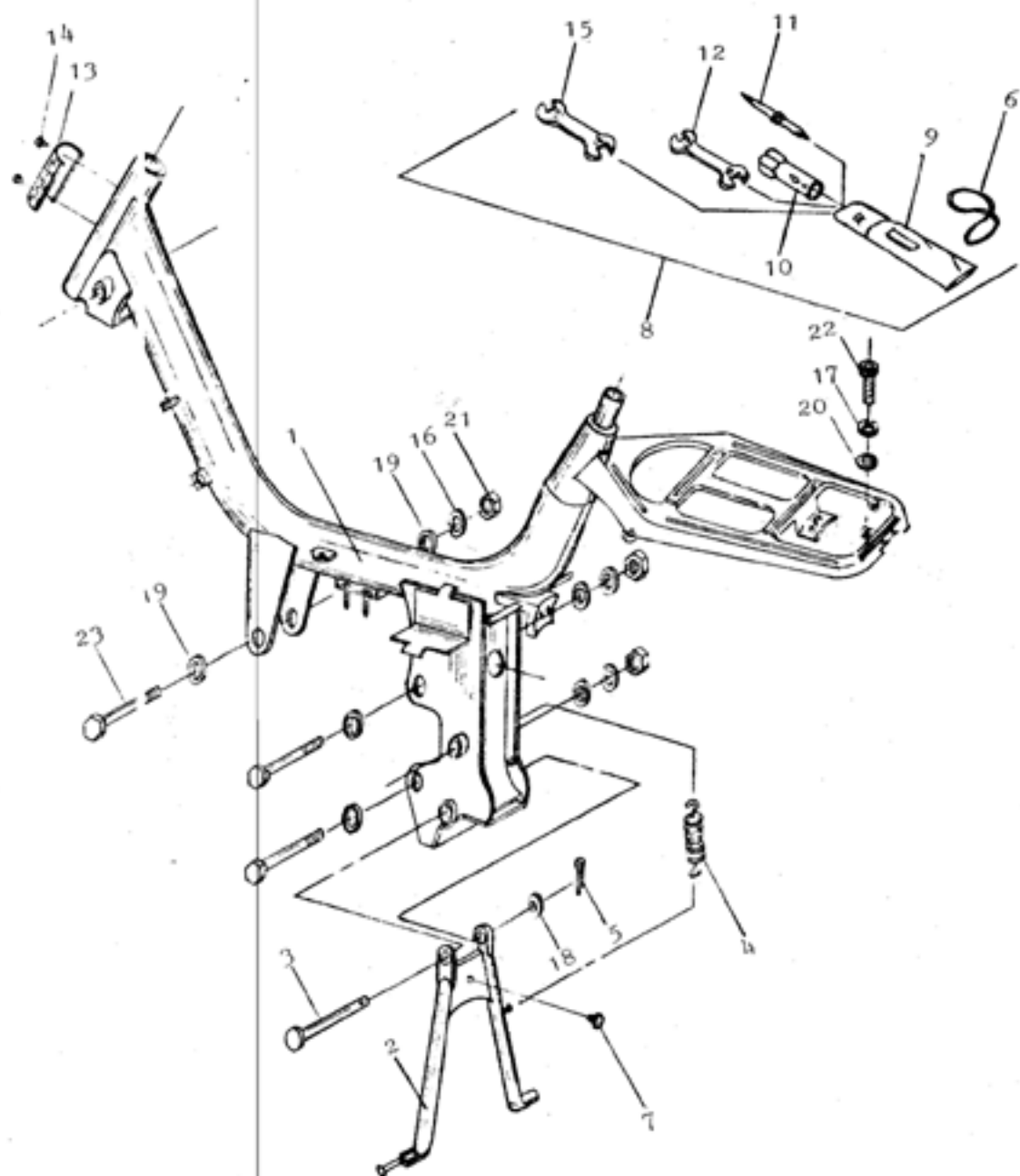

TABLE-6

FRAME ASSEMBLY

REF NO.	PART NO.	QUANTITY	DESCRIPTION
1	4150-6699	1	FRAME ASSEMBLY
2	3150-6667	1	MAIN STAND
3	1150-6666	1	SHAFT MAIN STAND
4	1150-6665	1	SPRING MAIN STAND
5	1150-6664	1	COTTER PIN 25x1
6	1150-6662	1	O RING
7	1150-6659	1	GROMMET
8	1150-6656	1	TOOL SET (9-12, 15)
9	1150-6655	1	TOOL BAG
10	1150-6654	1	WRENCH SOCKET
11	1150-6653	1	DRIVER
12	1150-6652	1	END WRENCH 10x12
13	3150-6651	1	INFORMATION PLATE
14	1150-6649	2	RIVET (3mm)
15	1150-6648	1	END WRENCH 14x17
16	6220-1108	3	SPRING WASHER 8mm
17	6220-1106	1	SPRING WASHER 6mm
18	6210-0110	1	PLAIN WASHER 10mm
19	6210-0108	6	PLAIN WASHER 8mm
20	6210-0106	1	PLAIN WASHER 6mm
21	6160-0108	3	NUT 8mm
22	6120-6015	1	SCREW 6x15
23	6110-8070	3	BOLT 8x70

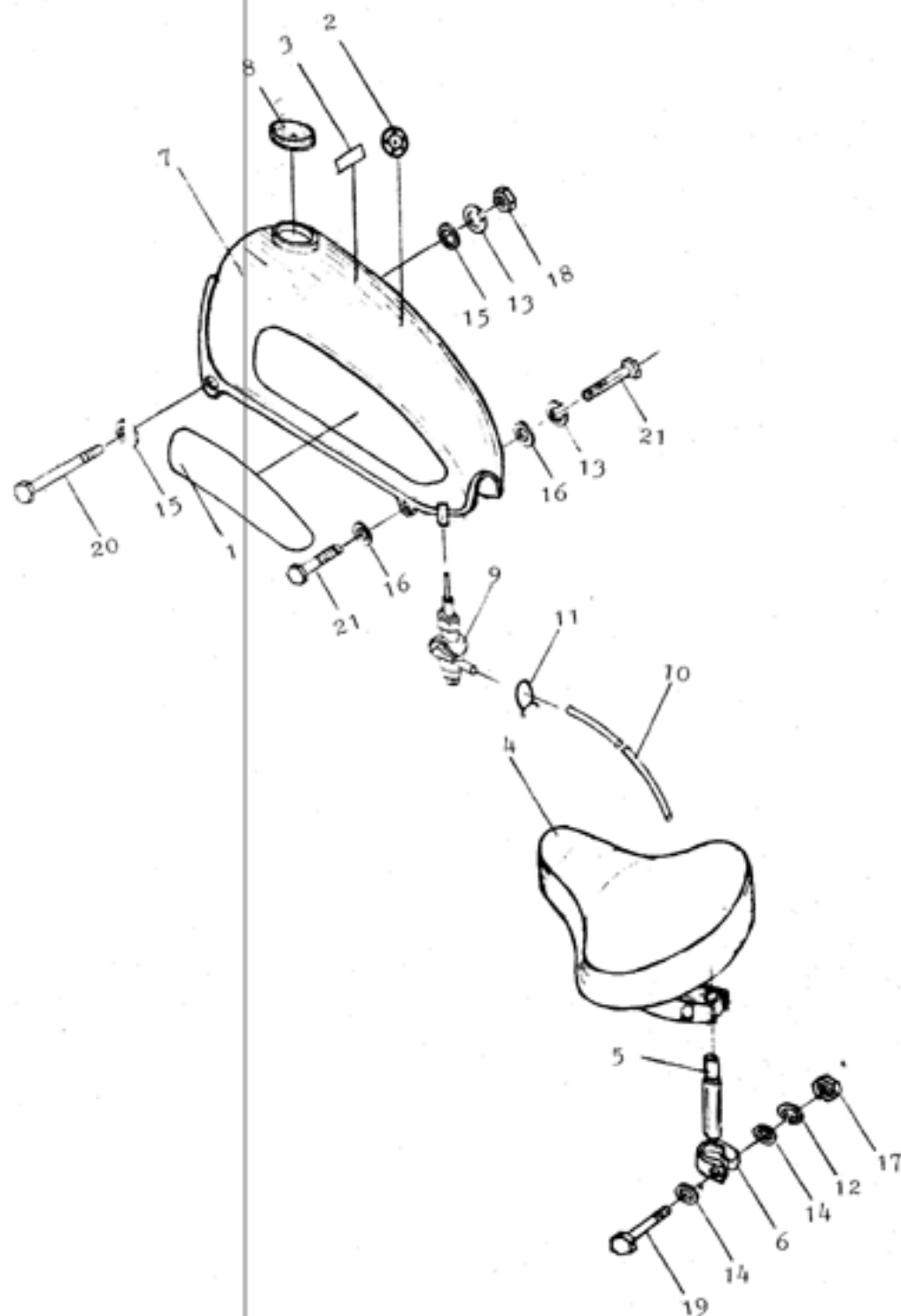

TABLE-7.

FUEL TANK & SEAT

REF NO.	PART NO.	QUANTITY	DESCRIPTION
1	4150-9099	1	DECAL, FUEL TANK L/H
	4150-9098	1	DECAL, FUEL TANK R/H
2	3150-9092	1	DECAL, FUEL TANK
3	3150-9091	1	DECAL REMINDER
4	2150-7699	1	SEAT ASSEMBLY
5	2150-7698	1	SUPDORTING TUBE
6	2150-7697	1	BEND
7	2150-7299	1	FUEL TANK
8	2150-7298	1	FUEL TANK CAP
9	4150-7295	1	FUEL COCK ASSEMBLY
10	2150-7294	1	FUEL HOSE
11	3150-7293	2	CLIP FUEL HOSE
12	6220-1110	1	SPRING WASHER 10mm
13	6220-1106	2	SPRING AASHER 6mm
14	6210-0110	2	PLAIN WASHER 10mm
15	6210-0108	2	PLAIN WASHER 8mm
16	6210-0106	2	PLAIN WASHER 6mm
17	6160-0110	1	NUT 10mm
18	6160-0106	1	NUT 6mm
20	6111-0045	1	BOLT 10x45
20	6110-6080	1	BOLT 6x80
21	6110-6012	2	BOLT 6x12

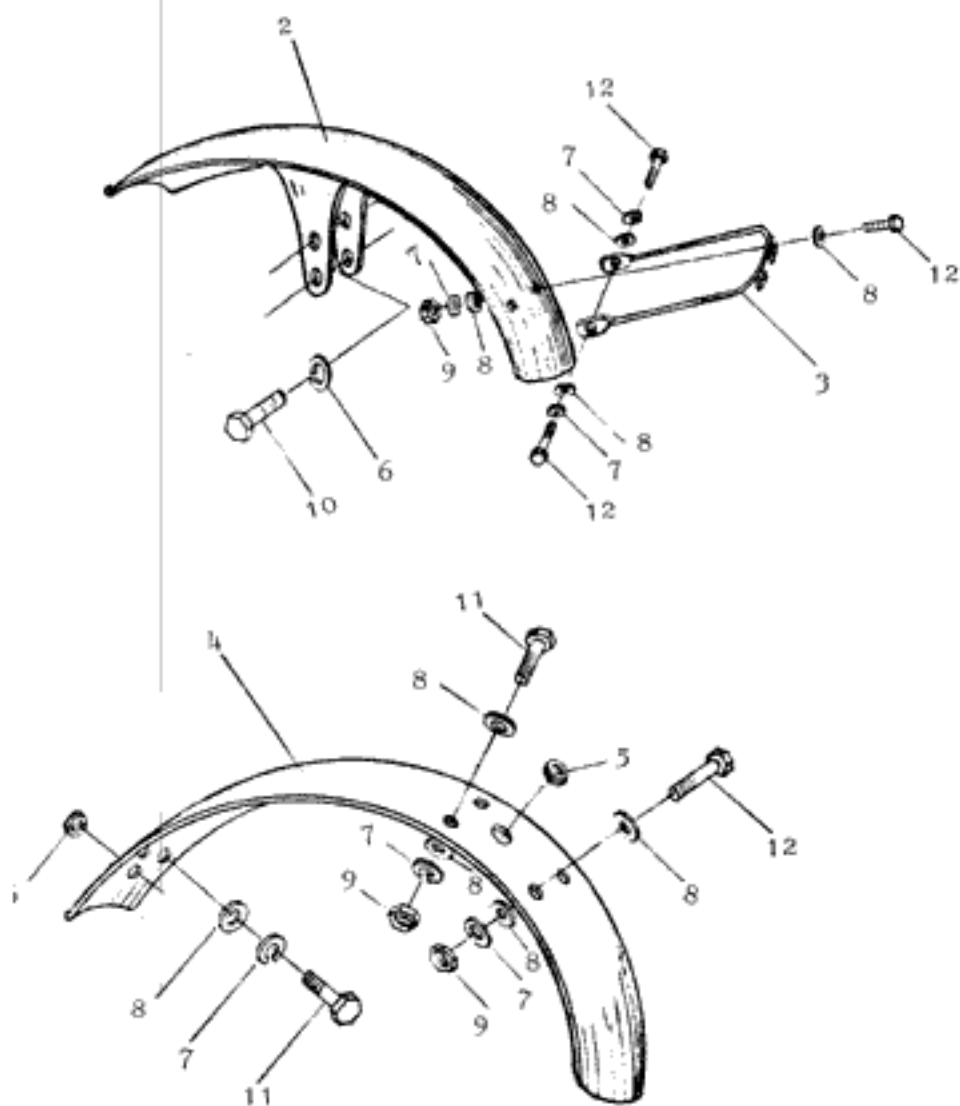

TABLE-8

FRONT FENDER & REAR FENDER

REF NO.	PART NO.	QUANTITY	DESCRIPTION
1	2150-7899	1	FRONT FENDER ASSEMBLY (2. 3. 7x2 8x4 9x2 12x2)
2	2150-7898	1	FRONT FENDER
3	2150-7897	1	SUPPORTING BAR
4	2150-7896	1	REAR FENDER
5	2150-7895	2	HUBBER
6	6220-1108	4	SPRING WASHER 8mm
7	6220-1106	10	SPRING WASHER 6mm
8	6210-0106	16	PLAIN WASHER 6mm
9	6160-0106	6	NUT 6mm
10	6110-8010	4	BOLT 8x10
11	6110-6015	4	BOLT 6x15
12	6110-6012	6	BOLT 6x12

SPEEDOMETER ASSEMBLY

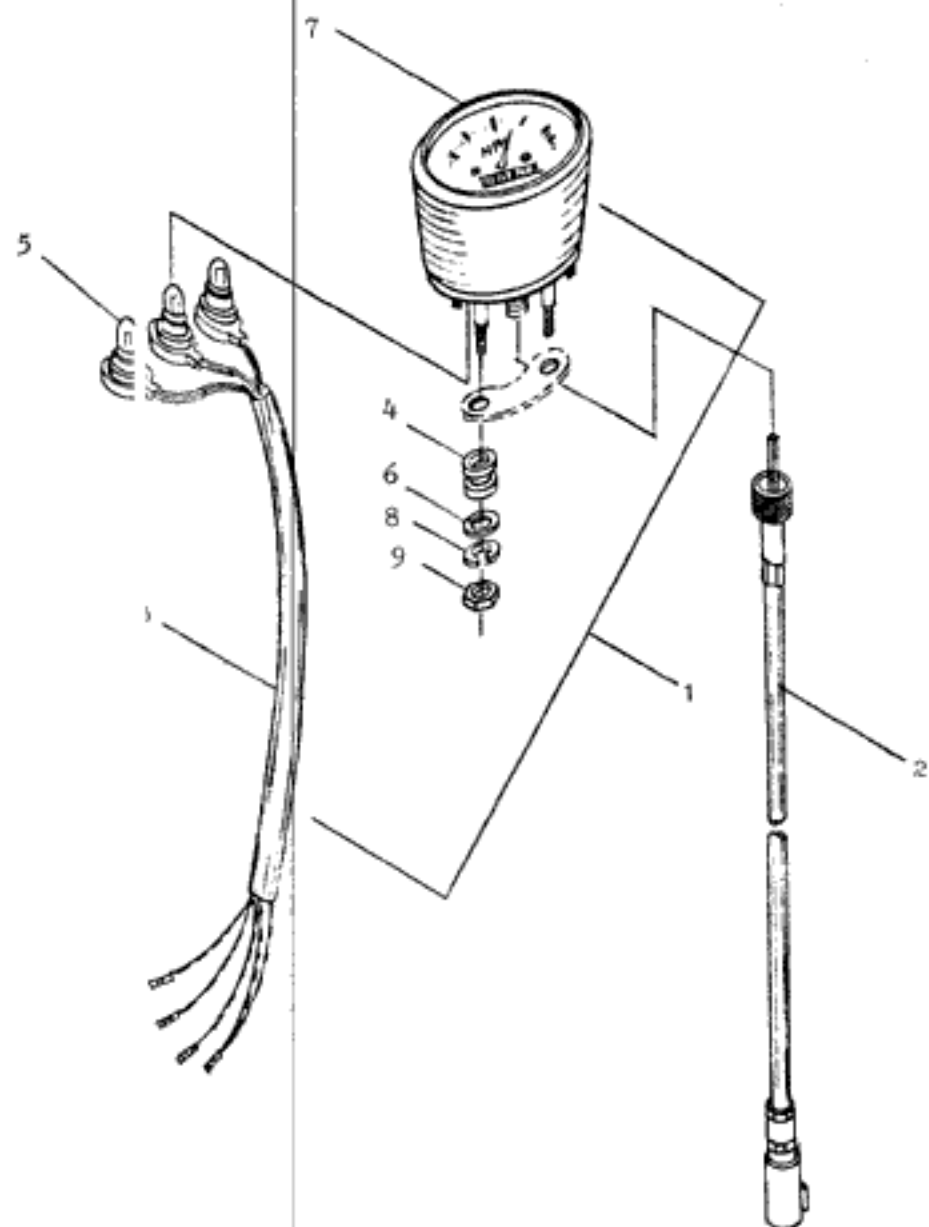

TABLE-9

SPEEDOMETER ASSEMBLY

REF NO.	PART NO.	QUANTITY	DESCRIPTION
1	1150-8099	1	SPEEDOMETER ASSEMBLY (WITHOUT 2)
2	1150-8097	1	CABLE SPEEDOMETER
3	1150-8096	1	WIRE HARNESS SPEEDOMETER
4	1150-8095	2	GROMMET
5	1150-8094	3	LAMP 6V 1.5W
6	1150-8093	2	PLAIN WASHER
7	1150-8092	1	SPEEDOMETER
8	6220-1106	2	SPRING WASHER 6mm
9	6160-0106	2	NUT 6mm

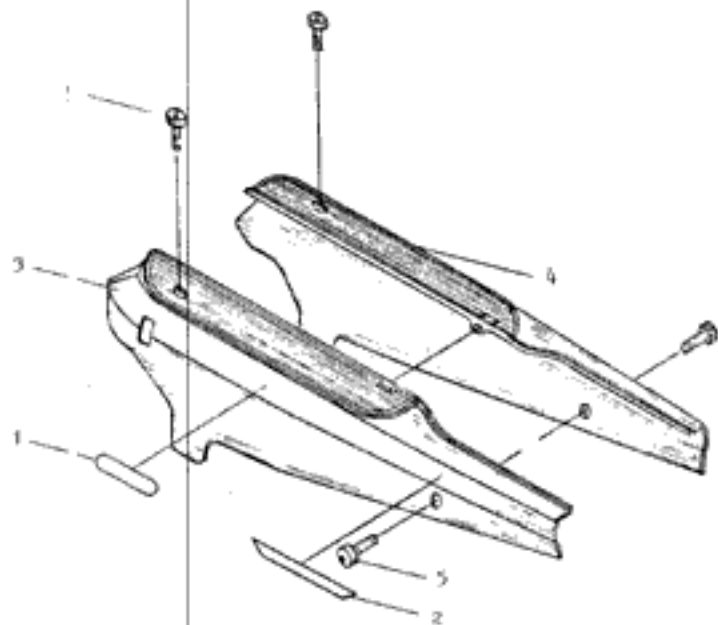

TABLE-1)

CHAIN COVER

REF NO.	PART NO.	QUANTITY	DESCRIPTION
1	4150-9097	2	DECAL CHAIN COVER L/H & R/H
2	4150-9095	1	DECAL CHAIN COVER L/H
	4150-9094	1	DECAL CHAIN COVER R/H
3	2150-7892	1	CHAIN COVER L/H
4	2150-7891	1	CHAIN COVER R/H
5	3150-7889	4	SCREW

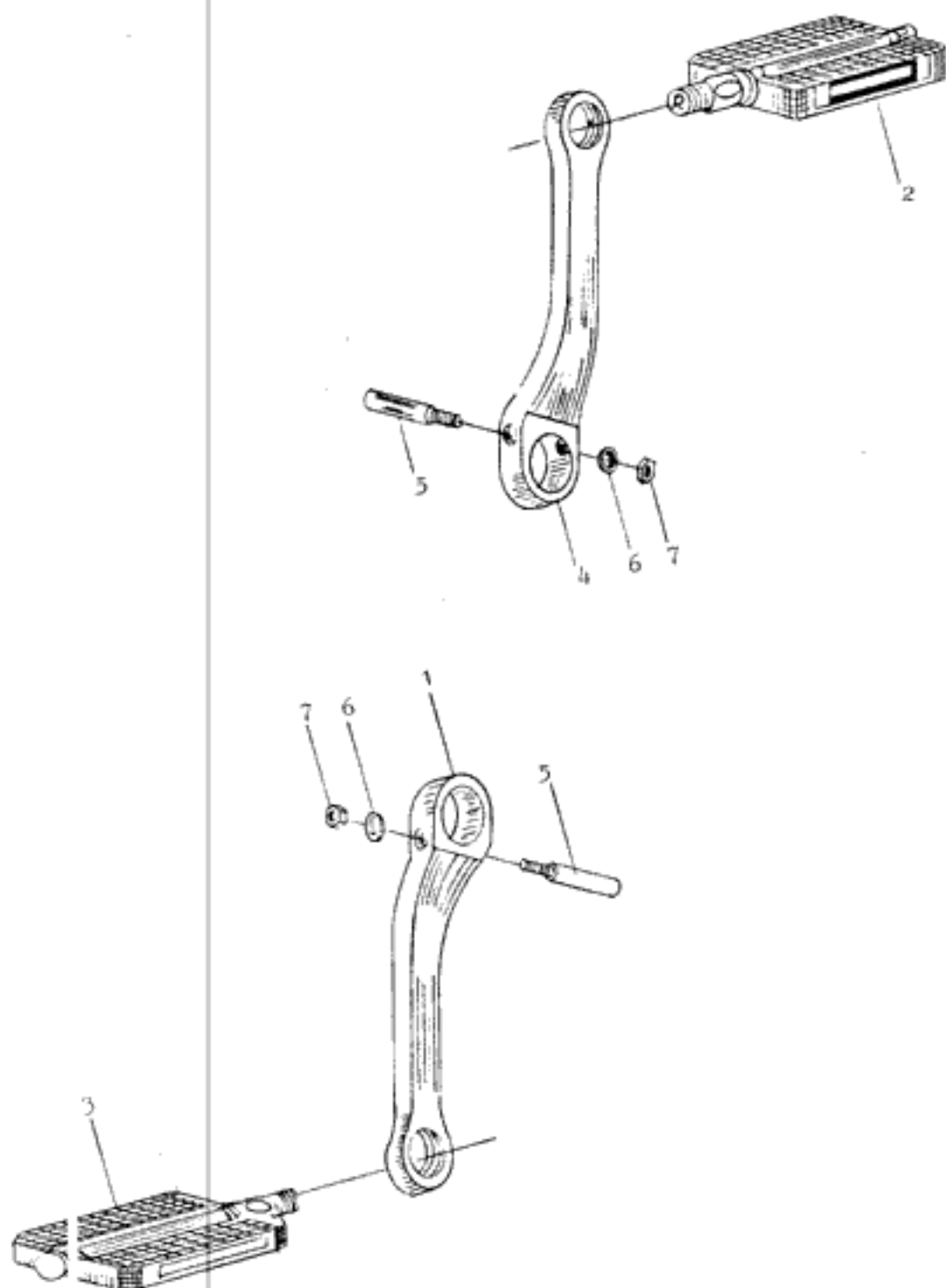

TABLE-1

CRANK & PEDAL ASSEMBLY

REF NO.	PART NO.	QUANTITY	DESCRIPTION
1	2150-9299	1	CRANK L/H
2	1150-9298	1	PEDAL ASSEMBLY R/H
3	1150-9297	1	PEDAL ASSEMBLY L/H
4	2150-9296	1	CRANK R/H
5	2150-9295	2	COTTER
6	6210-0106	2	PLAIN WASHER 6mm
7	6160-0106	2	NUT 6mm

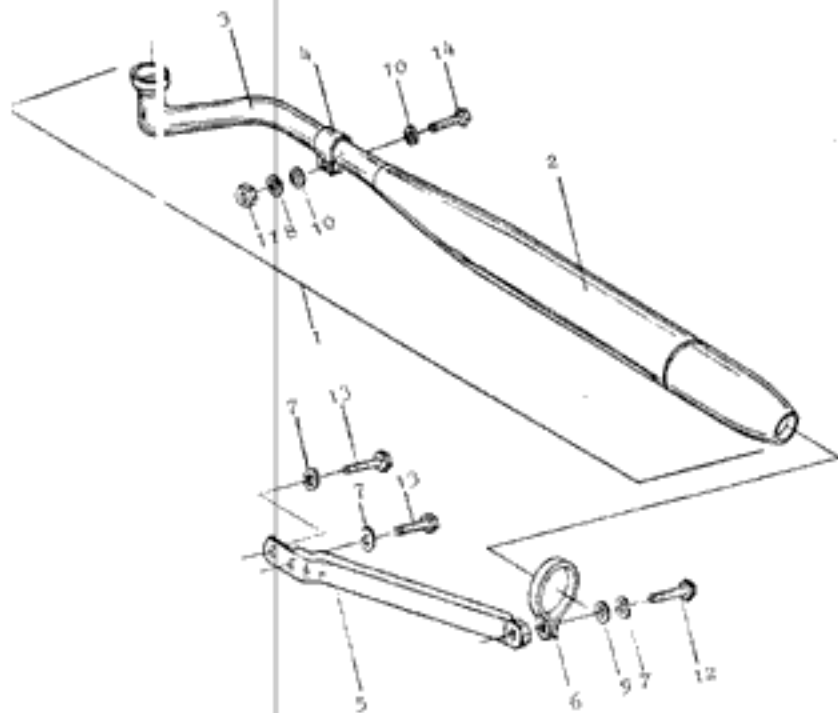

TABLE-12

MUFFLER ASSEMBLY

REF NO.	PART NO.	QUANTITY	DESCRIPTION
1	2150-7099	1	MUFFLER ASSEMBLY (2. 3. 4. 8. 10x2. 11. 14)
2	2150-7098	1	MUFFLER BODY
3	2150-7097	1	EXHAUST PIPE
4	2150-7094	1	BEND
5	2150-7093	1	SUPPORTING ARM
6	2150-7092	1	BEND
7	6220-1108	3	SPRING WASHER 8mm
8	6220-1106	1	SPRING WASHER 6mm
9	6210-0108	1	PLAIN WASHER 8mm
10	6210-0106	2	PLAIN WASHER 6mm
11	6160-0106	1	NUT 6mm
12	6110-8025	1	BOLT 8x25
13	6110-8015	2	BOLT 8x15
14	6110-6018	1	BOLT 6x18

TURN SIGNAL ASSEMBLY

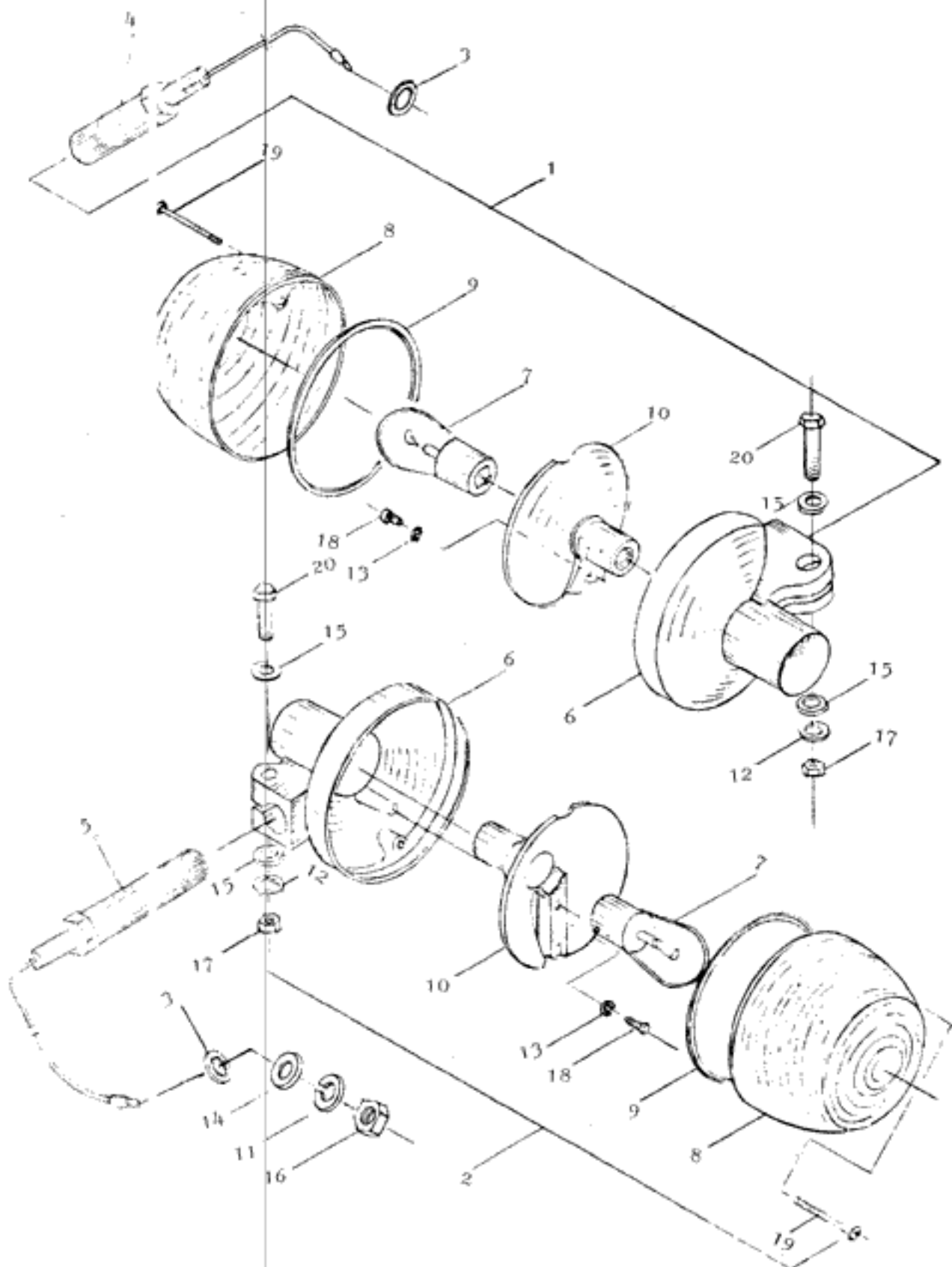

TABLE-13

TURN SIGNAL ASSEMBLY

REF NO.	PART NO.	QUANTITY	DESCRIPTION
1	3150-8299	1	FRONT TURN SIGNAL ASSEMBLY L/H
	3150-8298	1	FRONT TURN SIGNAL ASSEMBLY R/H
2	3150-8297	1	REAR TURN SIGNAL ASSEMBLY L/H
	3150-8296	1	REAR TURN SIGNAL ASSEMBLY R/H
3	1150-8295	4	LOCK WASHER INTERNAL TOOTH 10mm
4	3150-8294	2	BRACKET BAR FRONT
5	3150-8293	2	BRACKET BAR REAR
6	3150-8292	4	SOCKET
7	1150-8291	4	LAMP 6V 8W
8	1150-8290	4	LENS
9	1150-8288	4	GASKET
10	1150-8287	4	BULB SOCKET
11	6220-1110	2	SPRING WASHER 10mm
12	6220-1106	2	SPRING WASHER 6mm
13	6220-1105	4	SPRING WASHER 5mm
14	6210-0110	2	PLAIN WASHER 10mmmm
15	6210-0106	8	PLAIN WASHER 6mm
16	6160-0110	2	NUT 10mm
17	6160-0106	4	NUT 6mm
18	6130-5006	4	SCREW 5x6
19	6130-3023	8	SCREW 3x23
20	6110-6030	4	BOLT 6x30

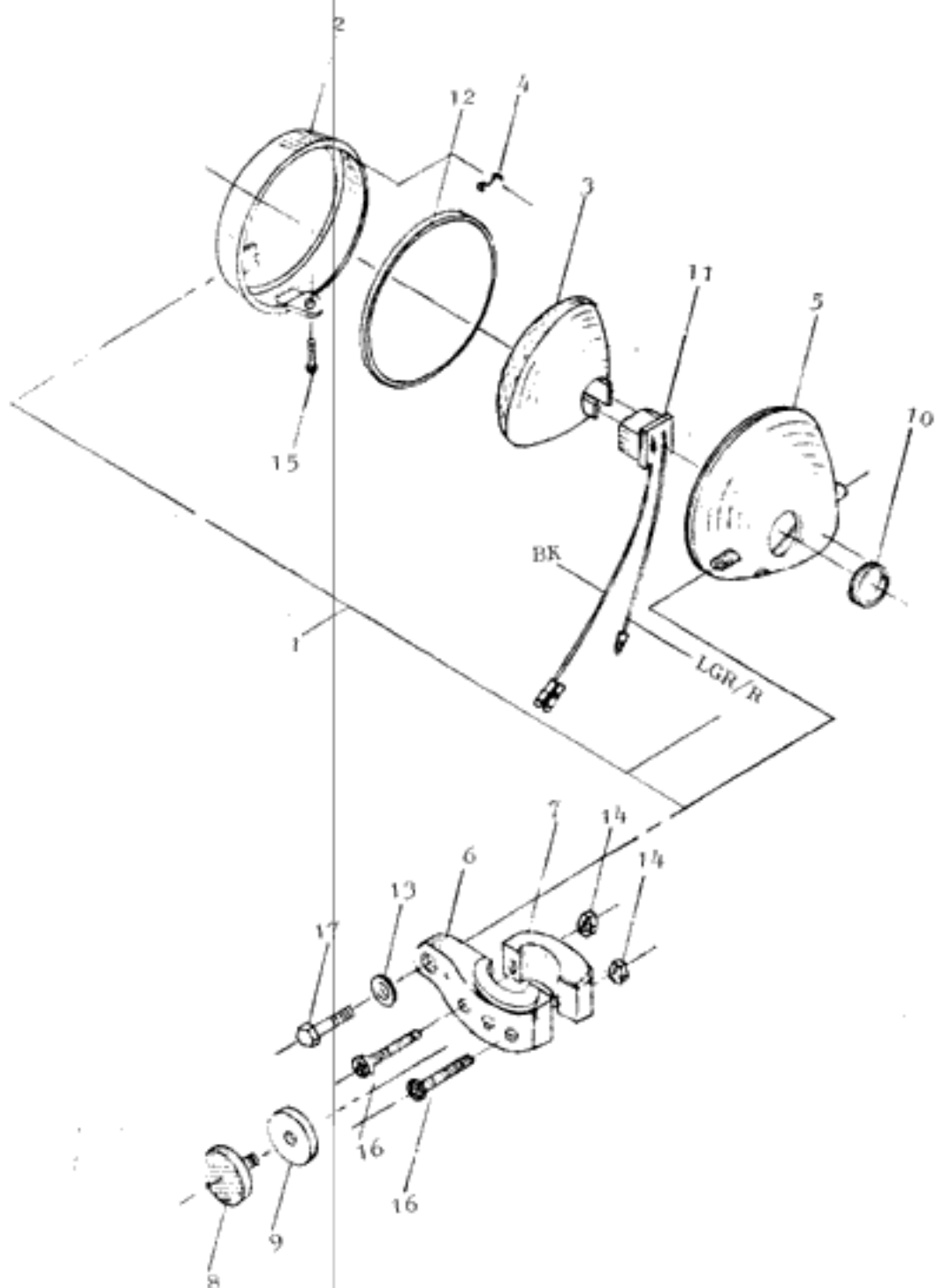

TABLE-1

HEAD LIGHT ASSEMBLY

REF NO.	PART NO.	QUANTITY	DESCRIPTION
1	2150-8499	1	HEAD LIGHT ASSEMBLY (2-5. 10-12. 14.)
2	1150-8498	1	RIM HEAD LIGHT
3	1150-8497	1	SEALED BEAM GE 4667
4	1150-8496	4	MOUNTING SPRING
5	1150-8495	1	CASE
6	3150-8494	2	BRACKET A, HEAD LIGHT (6mm)
7	3150-8493	2	BRACKET B, HEAD LIGHT
8	4150-5865	2	AMBER REFLECTOR
9	2150-5864	2	REFLECTOR GASKET
10	1150-8490	1	RUBBER HEAD LIGHT
11	2150-8489	1	HARNES ADAPTER
12	1150-8488	1	GASKET HEAD LIGHT
13	6210-0110	2	PLAIN WASHER 10mm
14	6160-0106	4	NUT 6mm
15	6130-5010	1	SCREW 5x10
16	6120-6020	4	SCREW 6x20
17	6111-0020	2	BOLT 10x20

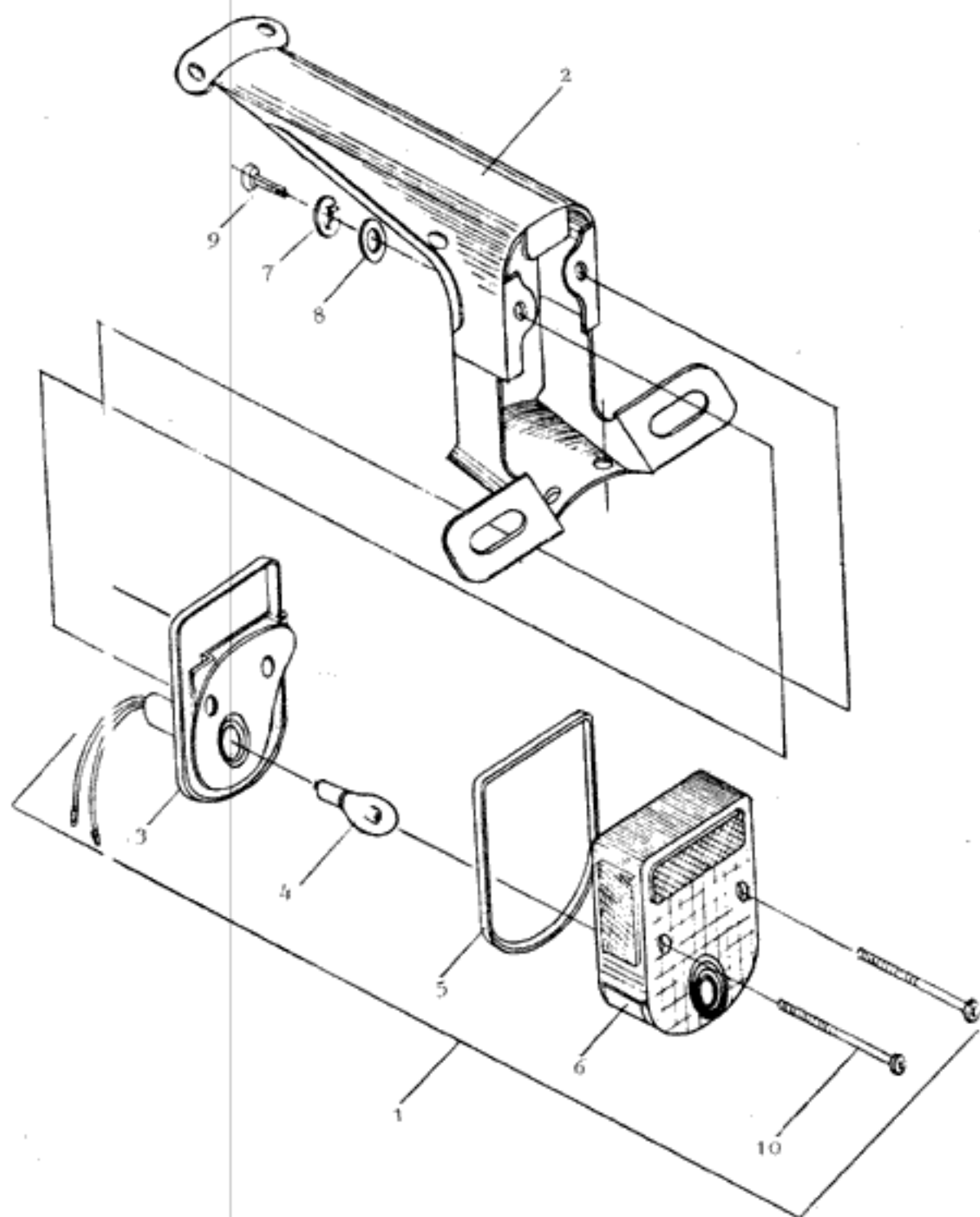

TABLE- 5

TAIL LIGHT ASSEMBLY

REF NO.	PART NO.	QUANTITY	DESCRIPTION
1	2150-8699	1	TAIL LIGHT ASSEMBLY
2	4150-8698	1	TAIL LIGHT BRACKET
3	2150-8697	1	BODY ASSEMBLY
4	2150-8696	1	BULB 6V 21/3CP
5	2150-8695	1	GASKET
6	2150-8694	1	LENS
7	6220-1105	2	SPRING WASHER 5mm
8	6210-0105	2	PLAIN WASHER 5mm
9	6130-5015	2	SCREW 5x15
10	6130-4050	2	SCREW 1/4x50

A	1	HEAD LIGHT
B	1	FRONT FURN LIGHT
C	7	FRONT STOP S.W.
D	7	METER LIGHT
E	7	LOCK
F	7	HANDLE S.W. R/H
G	7	HANDLE S.W. L/H
H	7	TAIL LIGHT
I	7	REAR TURN LIGHT
J	7	ENGINE

BL/	R	BLUE/BLACK
LGR	R	LIGHTGREEN/RED
Y		YELLOW
O		ORANGE
L		LIGHT BLOE
B		BROWN
R/		RED/WHITE
W		WHITE
G		GREY
F		BLUE

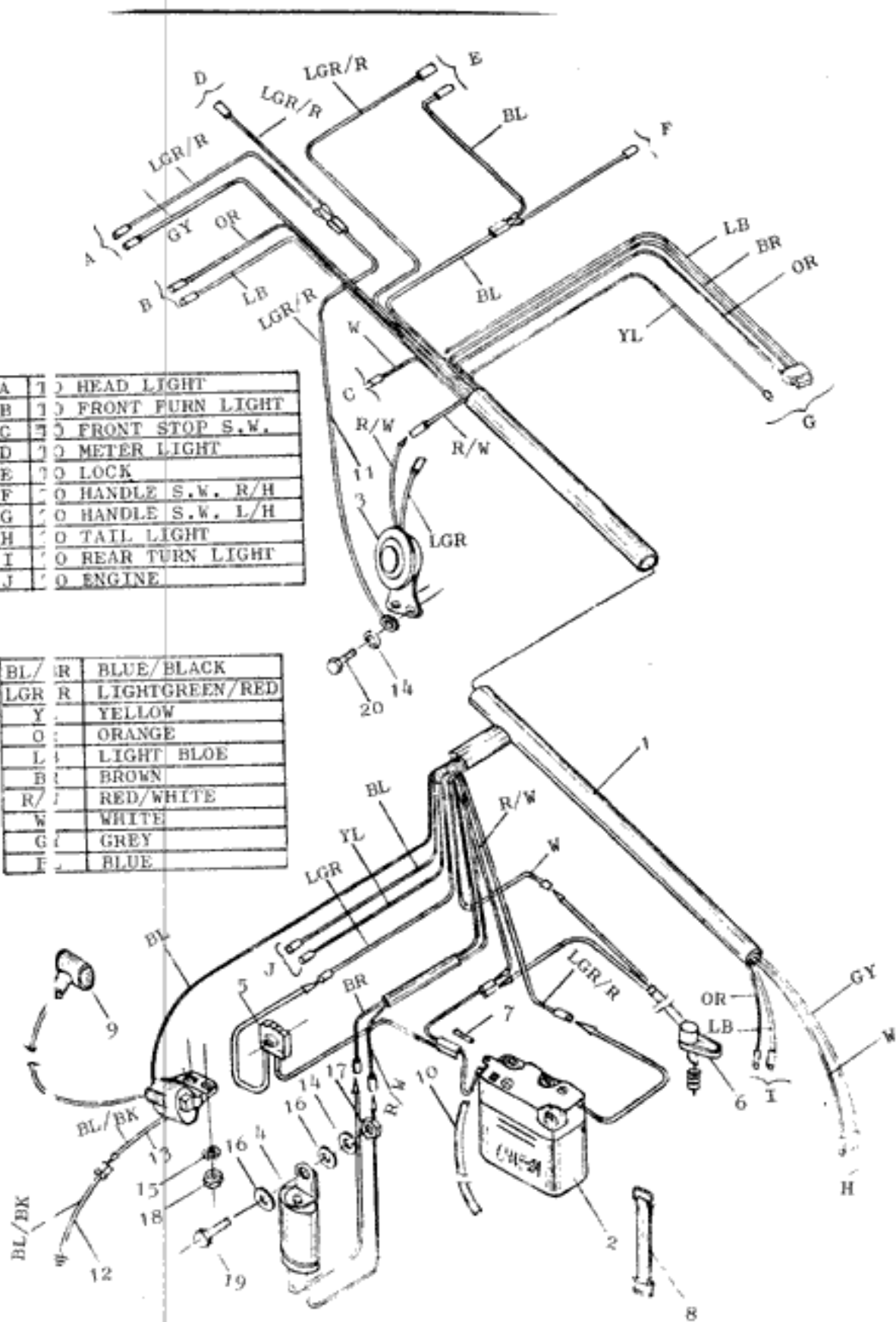

TABLE-16

WIRE HARNESS & ELECTRICITY

REF NO.	PART NO.	QUANTITY	DESCRIPTION
1	150-8899	1	WIRE HARNESS ASSEMBLY
2	150-8898	1	BATTERY 6N4B-2A
3	150-8897	1	HORN
4	150-8896	1	FLASHER
5	150-8895	1	RECTIFIER
6	150-8894	1	BRAKE SWITCH ASSEMBLY
7	150-8892	1	FUSE 10A
8	150-8890	1	BATTERY STRAP
9	150-8888	1	SPARK PLUG CAP
10	150-8887	1	FOSE
11	150-8885	1	EARTH WIRE A
12	150-8884	1	EARTH WIRE B
13	150-8883	1	CONNECTING WIRE
14	220-1106	2	SPRING WASHER 6mm
15	220-1105	2	SPRING WASHER 5mm
16	210-0106	2	PLAIN WASHER 6mm
17	160-0106	2	NUT 6mm
18	160-0105	2	NUT 5mm
19	110-6035	1	BOLT 6x35
20	110-6012	1	BOLT 6x12

TABLE-17

CRANKCASE, CRANKSHAFT, PISTON, CYLINDER, DECOMPRESSOR, INTAKE PIPE

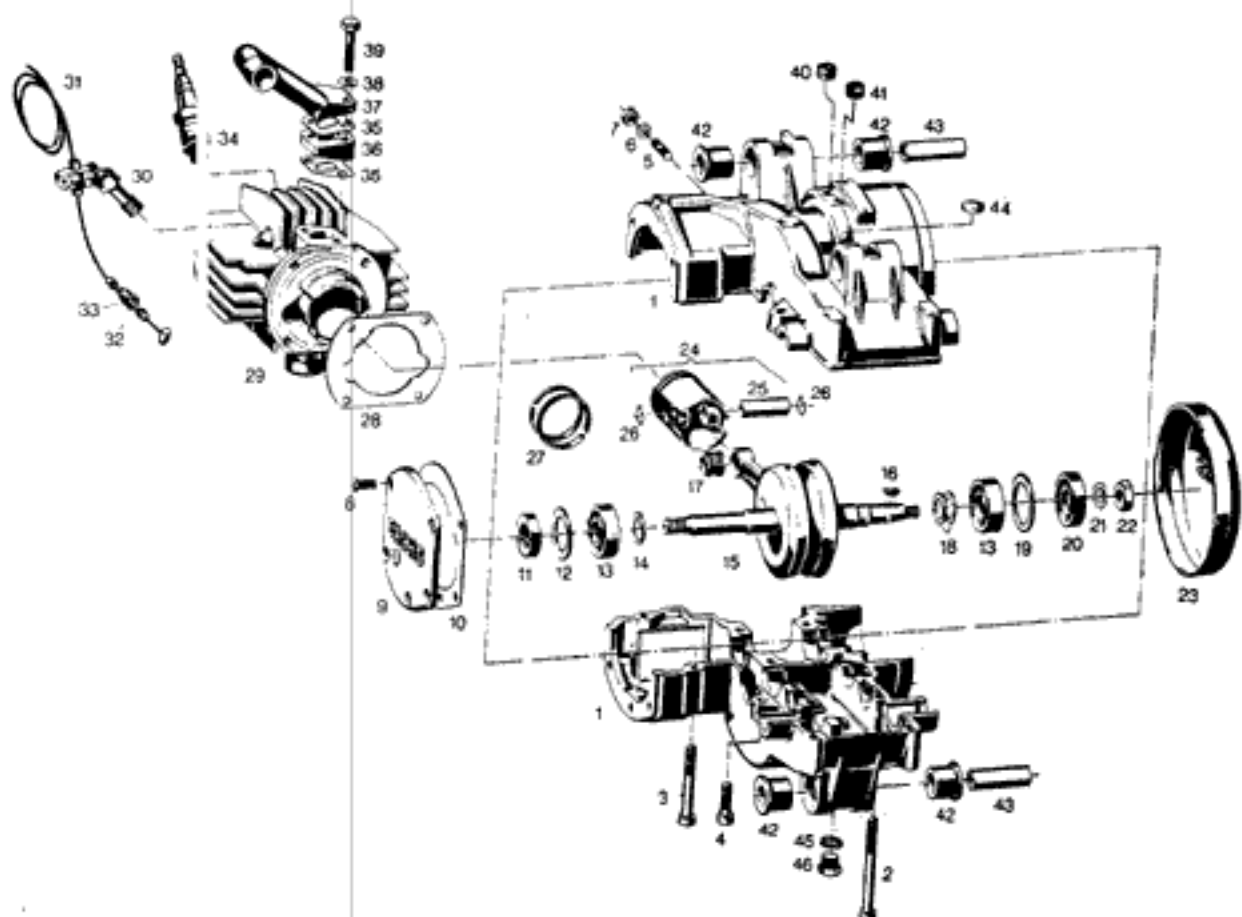

REF. NO.	PART. NO.	/1A	/1B	DESCRIPTION
1	0287-140-000 0287-140-003	1	1	Crankcase ass'y * Crankcase ass'y * in connection with Fig. 42 and 43
2	0240-176-002	10	10	Fillister head screw M 6x70
3	0640-003-002	4	4	Fillister head screw M 6x55
4	0640-001-001	1	1	Fillister head screw M 6x22
5	0240-058-101	4	4	Stud M 6x20
6	0944-142-002	4	4	Washer 6.2x12x1.5
7	0316-057-002	4	4	Hexagon nut M 6
8	0640-027-000	4	4	Oval head screw M 5 x 14
9	0277-117-000	1	1	Cover ass'y with 1x0250-131-000 gasket 1x0240-140-107 screw M 14x1 for oil level check
10	0250-155-200	1	1	Gasket

x = as required

TABLE-17

CRANKCASE, CRANKSHAFT, PISTON, CYLINDER, DECOMPRESSOR, INTAKE PIPE

REF. NO.	PART. NO.	/1A	/1B	DESCRIPTION
11	0230-107-000	1	1	Oil seal 15x30x5.5
12	0246-008-003	1	1	Washer 25.3x34x0.2
13	0232-120-001	2	2	Grooved ball bearing 6202 C3 DIN 625
14	0246-009-001	1	1	Washer 15.3x20x0.5
15	0288-114-000	1	1	Crankshaft
16	0246-005-000	1	1	Woodruff key 3x3.7
17	0232-157-001	1	1	Needle cage 12x15x13
18	0246-009-000	x	x	Washer 15.3x20, page 9
19	0244-153-000	1	1	Washer 30x36.8x1.5
20	0230-106-000	1	1	Oil seal 15x35x7
21	0245-022-000	1	1	Spring washer for M 10x1
22	0942-072-100	1	1	Collar nut M 10x1
23	0244-167-000	1	1	Cap
24	0286-378-005	1	1	Piston ass'y ϕ 38.0 } height
	0286-378-006	1	1	Piston ass'y ϕ 38.3 } 53 mm
25	0216-003-105	1	1	Gudgeon pin
26	0245-000-000	2	2	Wire spring ring
27	0215-009-000	2	2	Piston ring ϕ 38.0
28	0215-010-000	2	2	Piston ring ϕ 38.3
	0250-154-000	1	1	Gasket
29	0213-146-210		1	Cylinder
	0213-146-215	1		Cylinder
30	0291-022-200	1	1	Decompressor
31	0291-021-000	1	1	Cable ass'y with solder nipple } quote No. 0291-020-000 } required length
32	0291-024-011	1	1	Outer casing
33	0660-018-000	1	1	Protective cap
34	0998-004-001	1	1	Spark plug W 175 T 1 with SAE connecting nut
35	0250-156-100	2	2	Gasket
36	0211-152-000	1	1	Intermediate flange (not appli- cable for cylinder with flange)
37	0267-114-201	1	1	Intake pipe
	0244-114-203	1	1	Intake pipe
38	0244-100-008	2	2	Washer 6.2x10x1
39	0940-085-102	2	2	Hexagon head screw M 6x35
40	0960-136-000	1	1	Rubber grommet (1 hole)
41	0260-020-000	1	1	Rubber grommet (2 hole)
42	0251-121-000	6	6	Rubber mounting bush
43	0247-144-100	3	3	Distance tube
44	0244-168-000	1	1	Closing cap ϕ 13
45	1950-023-000	1	1	Sealing ring 10.5x14x1
46	1726-080-100	1	1	Screw plug M 10x1

x = as required

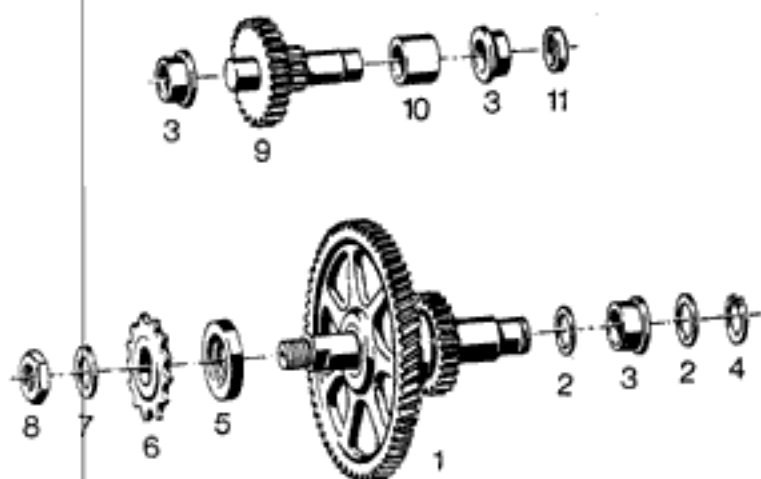

TABLE 18

GEAR

REF. NO.	PART. NO.	/1A	/1B	DESCRIPTION
1	0285-122-001	1	1	Mainshaft ass'y with layshaft, 39 bearing needles, bearing ring and fixed gear
2	0244-006-000	x	x	Washer 13.2x18, page 9
3	0232-155-000	3	3	Bush
4	0245-121-000	1	1	Circlip
5	0230-108-000	1	1	Oil seal 15x32x5.5
6	0236-105-101	1	1	Sprocket 11 teeth
7	0246-056-000	1	1	Washer
8	0642-005-101	1	1	Hexagon nut M 12x1
9	0285-123-000	1	1	Gearshaft ass'y with fixed gear
10	0247-105-000	1	1	Bush 13.6x18x14.3
11	0244-164-000	1	1	Closing cap ϕ 18

x = as required

CLUTCH

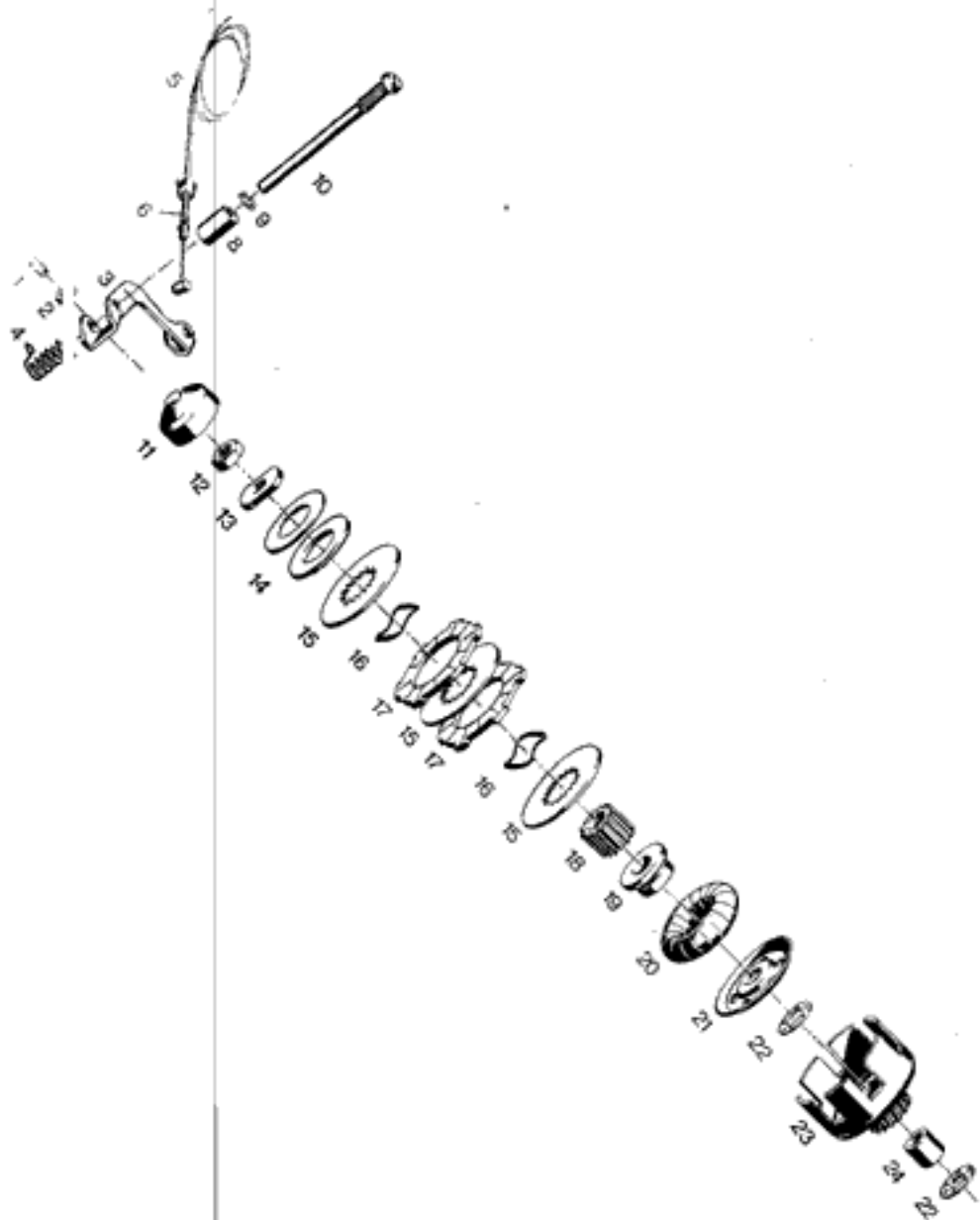

TABLE-19

CLUTCH

REF. NO.	PART. NO.	/1A	/1B	DESCRIPTION	
1	0640-107-100	1	1	Threaded pin M 8x1x13.5	
2	0242-121-000	1	1	Hexagon nut M 8x1	
3	0248-150-200	1	1	Clutch lever	
4	0239-136-200	1	1	Torsion spring	
5	0291-021-000	1	1	Cable ass'y with solder nipple No. 0291-020-000	} quote } required } length
6	0291-024-011	1	1	Outer casing	
7	0660-018-000	1	1	Protective cap	
8	0247-140-000	1	1	Bush 7.6x12x21.2	
9	1950-024-000	1	1	Sealing ring	
10	0240-181-102	1	1	Fillister head screw M 8x1	
11	0284-016-000	1	1	Pressure cup	
12	0242-000-000	1	1	Hexagon nut M 10x1	
13	0244-157-000	1	1	Washer	
14	0244-154-000	x	x	Washer 24.8x44 page 9	
	0244-154-003		1	Washer 24.8x44'x1.7	
15	0258-014-200	1	3	Internal plate 1.7mm thick	
	0258-014-101	2		Internal plate 2.5mm thick	
16	0245-122-100	2	2	Spring washer	
17	0258-015-000	2	2	External plate	
18	0258-012-000	1	1	Clutch hub	
19	0247-141-000	1	1	Ring	
20	0284-015-000	1	1	Centrifugal weight ass'y with 1 x 0239-137-100 tension spring	
21	0258-016 100	1	1	Clutch plate	
22	0244-112-000	2	2	Washer 11.9x23x1	
23	0284-014-000	1	1	Clutch case	
24	0232-132-101	1	1	Bush 11.7x16x16.5	

x = as required

MAGNETO-GENERATOR

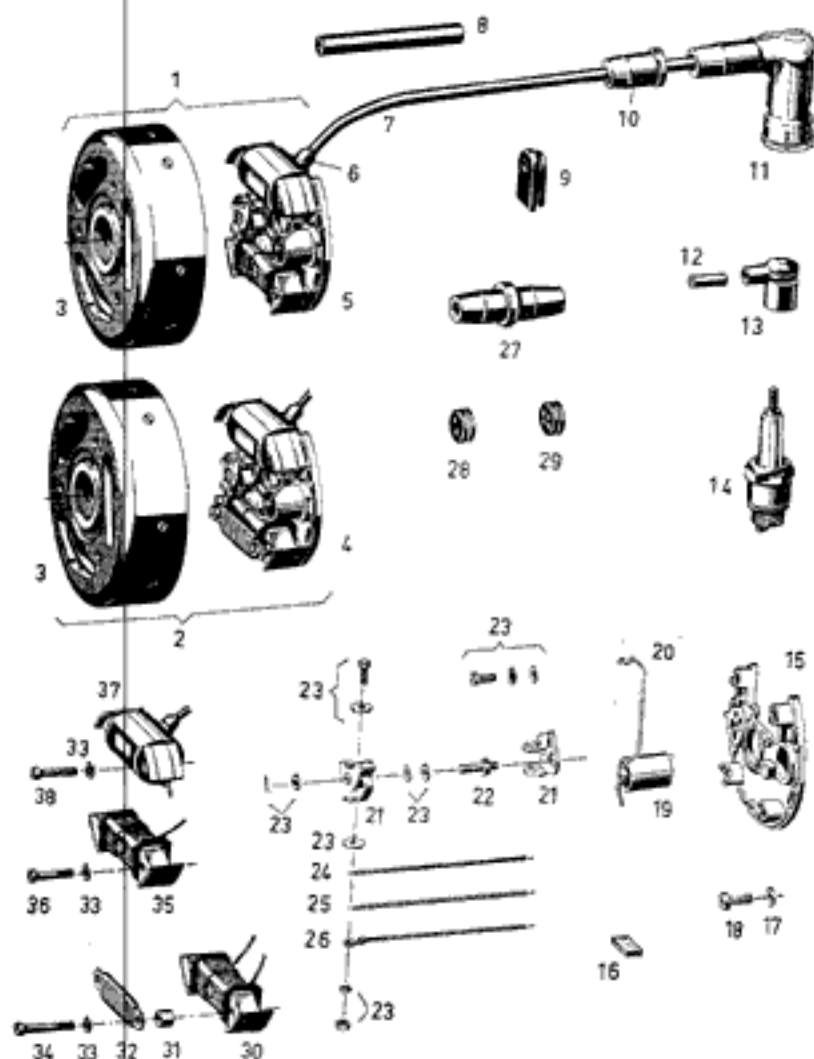

REF. NO.	PART. NO.	1/A	1/B	DESCRIPTION
1		1	1	Magneto-generator 6 volt 17 Watt only available under Fig. 3 and 5
2				
3	0286-175-005-	1	1	Flywheel for BOSCH:0212-112-019 0212-122-006
4				
5	0286-254-008	1	1	Armature base plate ass'y for BOSCH:0212-112-019

TABLE-2)

MAGNETO-GENERATOR

REF. NO.	PART. NO.	1/A	1/B	DESCRIPTION
6	2865-003-000	1	1	Protective cap against rain
7	0965-133-001	1	1	Ignition cablego
8	0263-121-001	1	1	Insulating hose
9		1	1	Cancelled
10	0265-109-000	1	1	Protective cap against rain
11	0265-100-100	1	1	Spark plug connector, partly suppressed
12	0960-116-000	1	1	Bush
13	0288-091-000			Spark plug connector, not suppressed
14	0998-004-001	1	1	Spark plug W 175 T1 with SAE connecting nut
15	0265-008-000	1	1	Armature base plate for BOSCH:0212-112-006
16	2865-008-000	1	1	Lubricating pad
17	0244-108-000	3	3	Washer 4.1x9x1.2
18	0240-106-100	3	3	Oval head screw M 4x14
19	0265-052-003	1	1	Condenser
20	0265-077-001	1	1	Connecting cable to condenser
21	0983-106-000	1	1	Set of contact breakers
22	0240-066-009	1	1	Bearing pin
23	0283-107-000	1	1	Set of spares for contact breakers
24	0299-059-009	1	1	Lighting cable quote
25	0299-059-016	1	1	Rear light cable required
	0299-059-021			Stop light cable length
26	1483-009-000	1	1	Short-circuiting cable
27	0265-073-000	2		Cable terminal
28	0260-020-000	1	1	Rubber grommet (2 hole)
29	0260-020-005			Rubber grommet (4 hole)
30	0265-139-001			Generating armature with 2 connections (lighting and stop light coiling) for BOSCH:0212-122-006
31	0247-106-001			Bush 4.3x8x7
32	0265-139-006			Rear light armature for BOSCH:0212-122-006
33	0246-023-000			Spring ring for M 4
34	0240-122-000			Fillister head screw M 4x13
35	0265-113-003	1	1	Generating armature for BOSCH:0212-112-019
36	0241-032-000	2	2	Fillister head screw M 4x23
37	0265-142-000	1	1	Ignition armature for BOSCH:0212-112-019 0212-122-006
38	0240-105-000	2	2	Fillister head screw M 4x21

PEDAL SHAFT

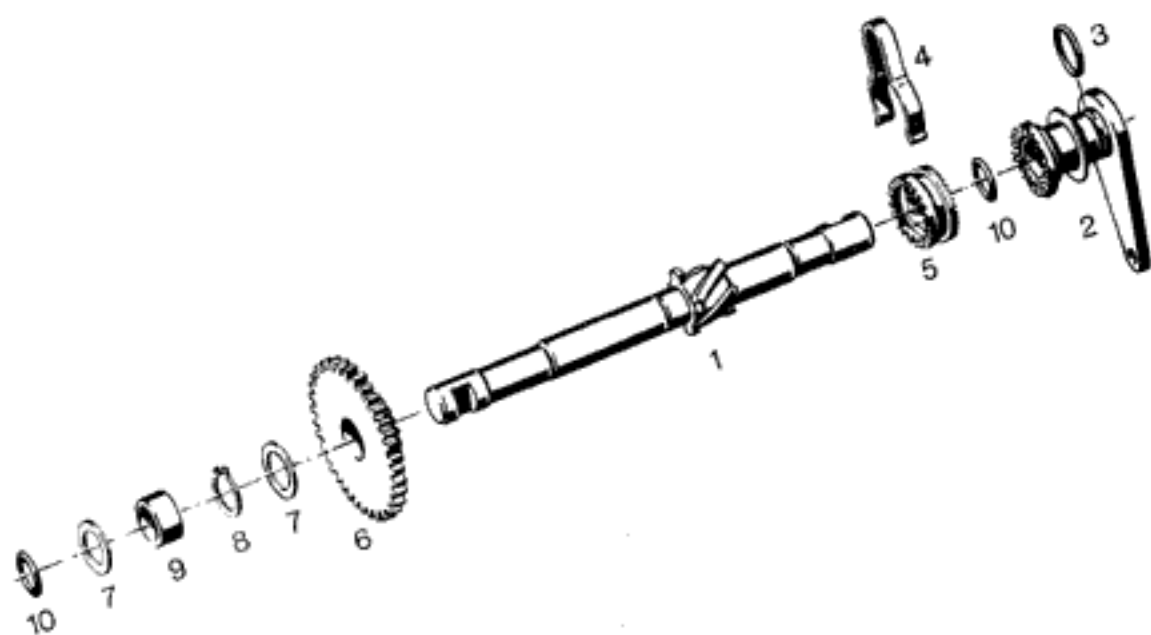

TABLE 21

PEDAL SHAFT

REF. NO.	PART. NO.	/1A	/1B	DESCRIPTION
1	0237-106-101	1	1	Pedal shaft
	0285-121-000	1	1	Pedal shaft ass'y with Fig. 6, 7 and 8
2	0285-120-000	1	1	Driver bush ass'y with washer and brake lever
3	0250-165-000	1	1	Round sealing ring 19x2
4	0239-051-001	1	1	Brake spring
5	0252-007-201	1	1	Driver
6	0234-106-001	1	1	Starting wheel
7	0944-120-002	2	2	Washer 16.2x22x1
8	0245-020-001	1	1	Circlip
9	0247-149-000	1	1	Bush 16.3x20x9.2
10	0250-164-000	2	2	Round sealing ring 13x1.5

CARBURETOR

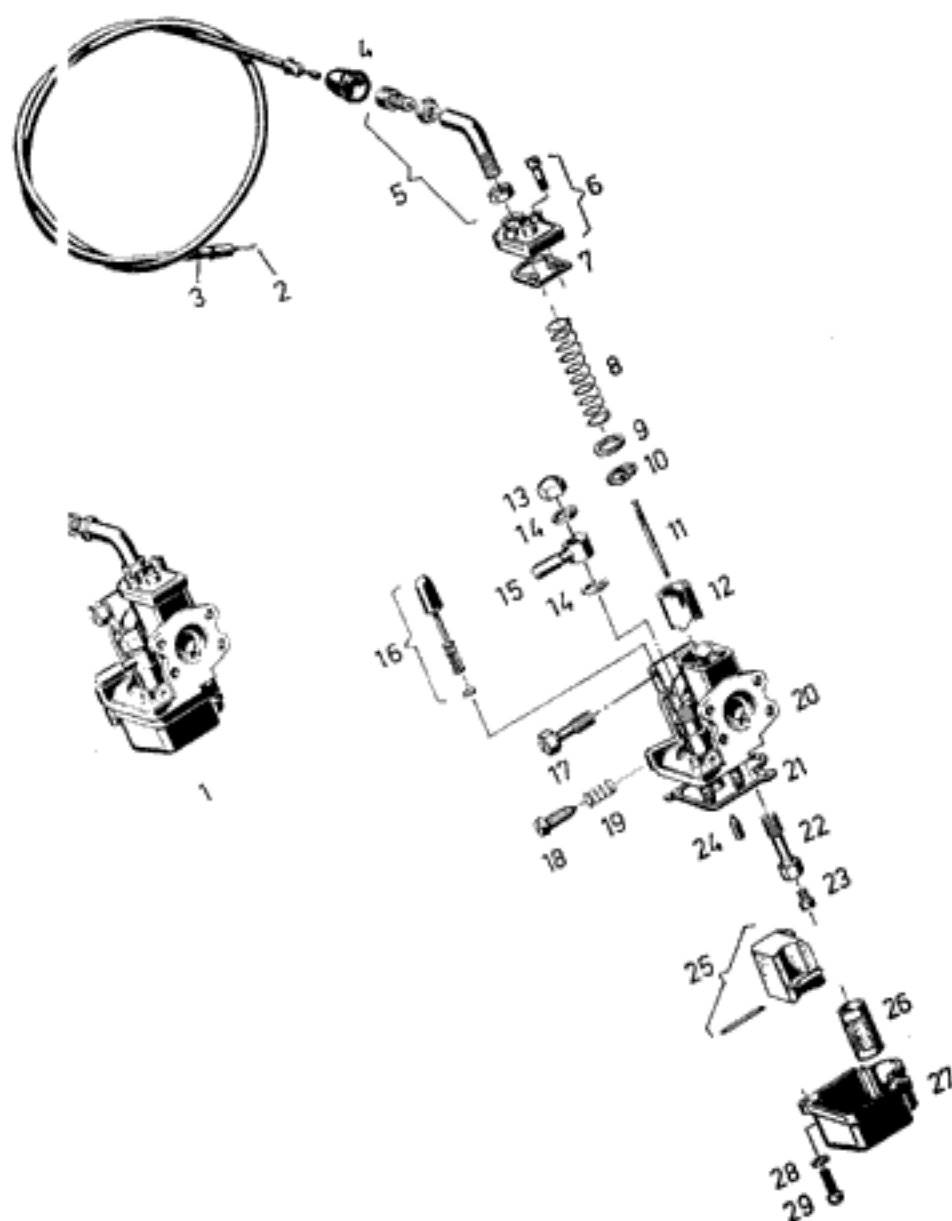
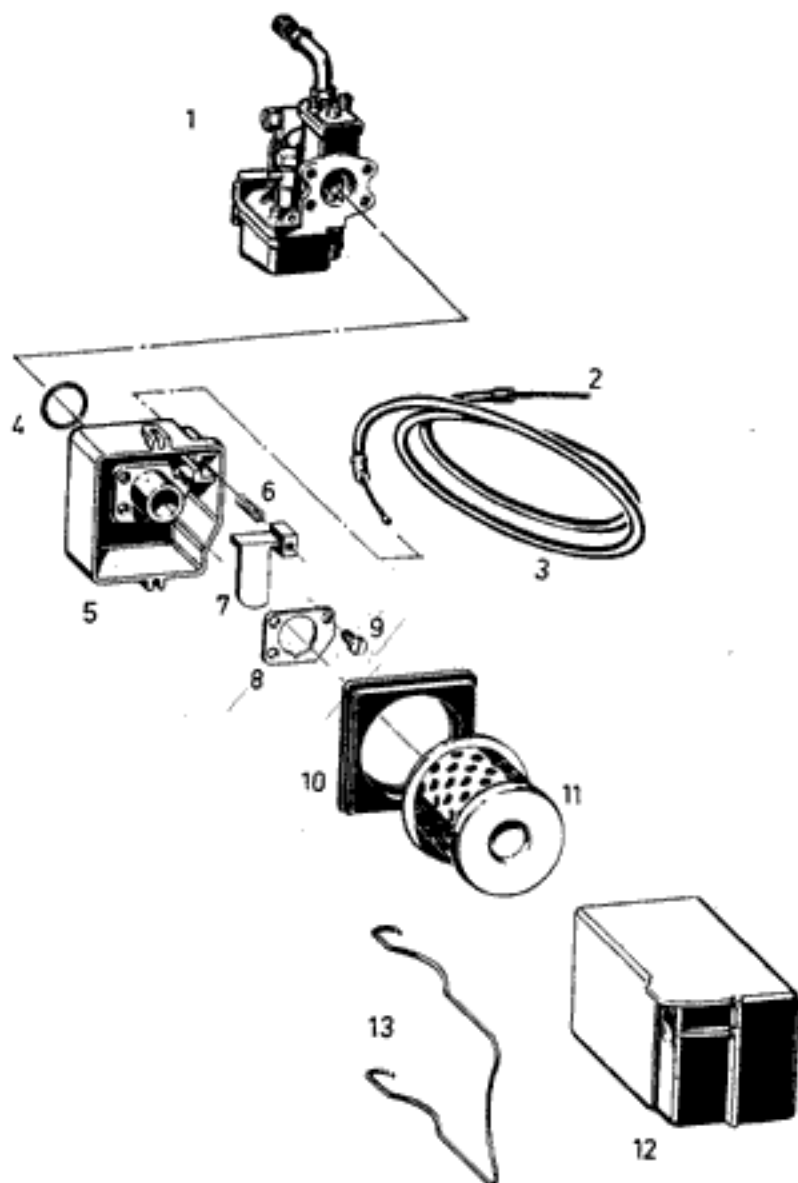

TABLE- 12

CARBURETOR

REF. NO.	PART. NO.	/1A	/1B	DESCRIPTION
1	0281-124-005	1		Carburetor ass'y BING mark 85/12/101 (main jet 52, needle position 11, needle jet 2,17)
	0281-124-000		1	Carburetor ass'y BING mark 85/10/101 (main jet 50, needle position 11, needle jet 2,17)
2	0291-004-000	1		Cable
				with solder nipple
				No. 0291-003-000
3	0291-024-001	1		Outer casing, black
	0291-024-011	1		Outer casing, silver-coloured
4	0260-024-001	1		Protective cap
5	0261-143-000	1	1	Pipe bend ass'y with 2x hexagon nut and adjusting screw
6	0261-144-000	1	1	Cover plate with fastening screw
7	0250-162-000	1	1	Gasket
8	0239-140-000	1	1	Slide spring
9	0244-109-000	1	1	Washer
10	0261-018-000	1	1	Small retaining plate
11	0261-006-003		1	Jet needle, 33 mm long
	0261-006-004	1		Jet needle, 36 mm long
12	0261-146-000	1	1	Throttle valve
	0261-148-000			Throttle valve
13	0242-110-000	1	1	Cap nut
14	0962-013-000	2	2	Sealing ring
15	0261-125-000	1	1	Hose connection
16	0281-109-000	1	1	Tickler ass'y with spring and forelock
17	0962-066-000	1	1	Clamping screw
18	0962-065-000	1	1	Adjusting screw
19	0962-065-000	1	1	Spring
20				Carburetor body, only available under Fig.1
21	0250-161-000	1	1	Gasket
22	0261-142-000	1	1	Needle jet 2.17
23	0247-143-000	1		Ring (in needle jet)
23	0961-151-000	1	1	Main jet (quote required size)
24				Available only under Fig.25
25	0281-125-000	1	1	Float ass'y with float needle and pin
26	0261-145-000	1	1	Screening sleeve
27	0261-141-000	1	1	Float chamber
	0261-141-001			Float chamber
28	0245-023-000	2	2	Spring ring for M 4
29	0241-028-001	2	2	Fillister head screw

INTAKE SILENCER



INTAKE SILENCER

REF. NO.	PART. NO.	/1A	/1B	DESCRIPTION
1				Carburettor ass'y see Fig.1/1
2	0291-004-000	1	1	Cable with solder nipple } quote No. 0291-003-000 } required length
3	0291-024-011	1	1	Outer casing, silver-coloured
4	0250-160-000	1	1	Round sealing ring 17x1.5
5	0225-007-100	1	1	Intake silencer housing
6	0239-138-000	1	1	Pressure spring
7	0225-009-000	1	1	Starting slide
8	0244-160-000	1	1	Shim
9	2015-007-004	2	2	Fillister head screw M 5x10
10	0225-011-000	1	1	Filter holder
11	0225-010-100	1	1	Micronic air filter, intake ϕ 16
12	0225-008-005	1		Intake silencer cap grey, intake ϕ 16
13	0239-139-000	1	1	Stirrup

REPAIR TOOLS AND MOUNTING JIG

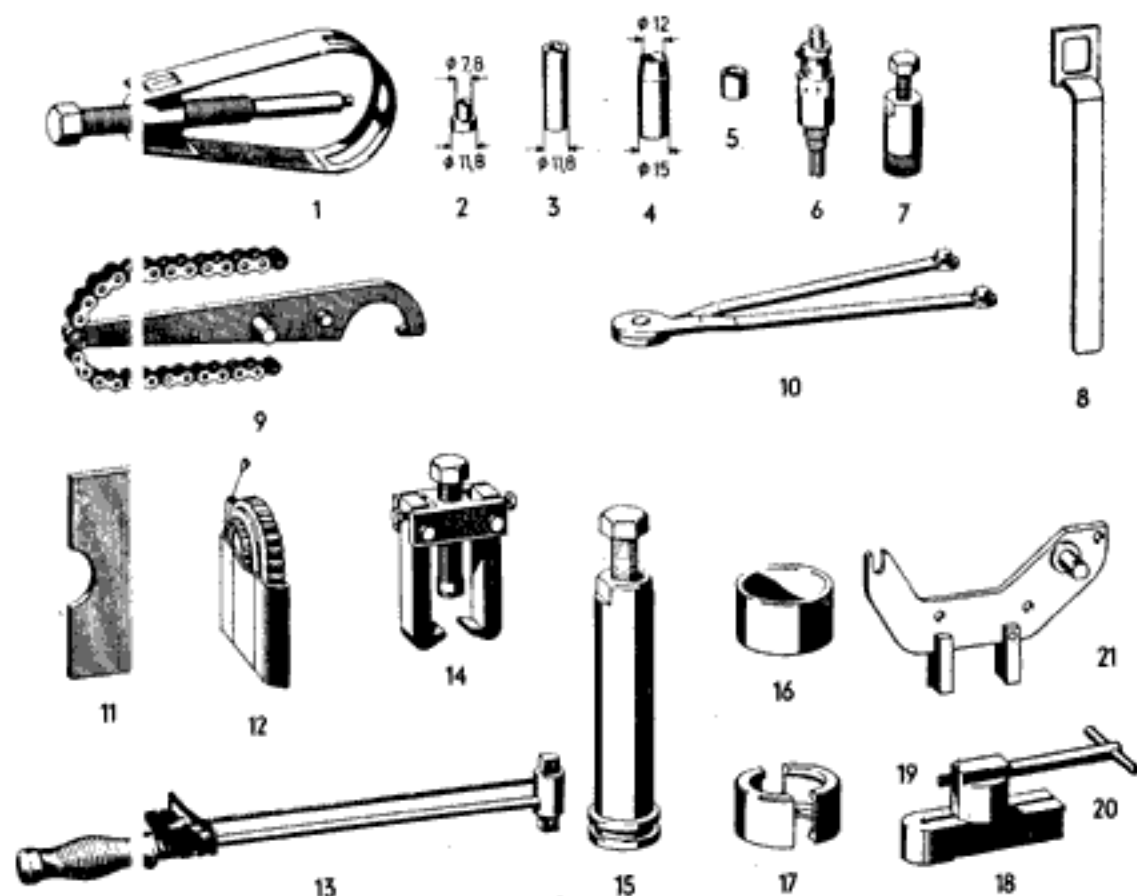

No.	Part No.	Description
Repair tools		
1	0276 065 101	Gudgeon pin extractor
2	0277 083 000	Insert bush for gudgeon pin extractor
3	0276 023 001	Gudgeon pin for piston
4	0278 022 005	Protective sleeve for crankshaft (power take-off side)
5	0276 156 000	Protecting cap, bore 10 mm
6	0276 135 100	Spark advance timing gauge
7	0276 150 005	Puller for magneto flywheel M 26 x 1.5
8	0276 182 000	Holding tool for clutch
9	0276 180 002	Hook wrench
10	0276 181 000	Pin spanner, adjustable
11	0276 019 101	Intermediate plate
12	0276 175 000	Revolution counter
13	0276 170 000	Torque wrench
14	0276 179 000	Puller for sprocket
15	1476 013 000	Puller sleeve ass'y.
	1476 011 000	Threaded sleeve
	1440 027 001	Hexagon bolt
	1476 012 000	Thrust bearing
16	1447 009 000	Clamping ring, inner dia. ϕ 58 mm (2.28")
17	1476 014 002	Puller shells for grooved ball bearing
Mounting jig		
18	0276 081 000	Clamping base
19	0276 082 000	Swivel unit
20	0276 085 005	Clamping screw
21	0276 088 006	Mounting bracket

OWNER TOOL KIT

OWNER TOOL KIT



1



2



3



4

REPAIR TOOLS



5

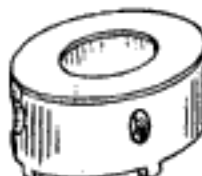

6

REF. NO.	PART. NO.	DESCRIPTION
1	1150-6648	Double end wrech 14/17 mm
2	1150-6625	Double end wrench 10/12 mm
3	1150-6654	Wrench socket
4	1150-6653	Screw driver "+" & "-"
5	1150-6644	Wrench for stem cap nut
6	1150-6654	Stem nut locking wrench

DISMANTLING THE ENGINE

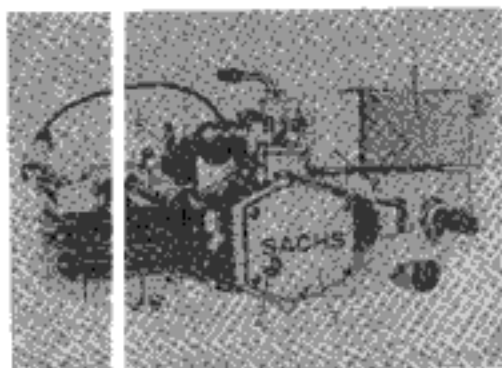

Bild/Fig. 1

Remove the engine from the frame and clean it thoroughly before dismantling.

Intake silencer, carburettor and intake pipe

Remove the intake silencer cap (1) and the micro-nic air filter with the filter frame.

Remove starter slide with control cable and pressure spring.

Unscrew carburettor and intake pipe (5). Remove gasket or gasket, intermediate flange and gasket.

Unscrew the intake silencer housing (2) only in case of necessity.

Unscrew cover (3) with gasket.

Drain the gearbox oil.

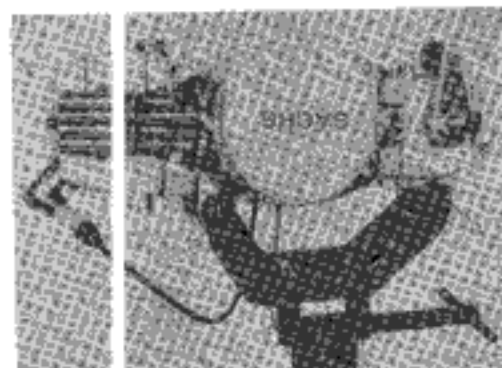

Bild/Fig. 2

Mount the engine

Mount the engine (lower part of crankcase upwards) with 2 hexagon head screws (1) M 8 x 65 and nuts to the mounting jig.

Cylinder

Unscrew the cylinder and remove the cylinder flange gasket.

Note:

The cylinder can be rebored once, to be used with the corresponding piston (see Spare Parts List). When fitting a new cylinder or a reconditioned cylinder with piston, the colour mark (red or white) on the piston crown and in the intake part of the cylinder must be of the same colour.

Piston and cover

Remove both wire circlips.

Push out the gudgeon pin with gudgeon pin extractor and insert bush (1).

Remove the needle cage.

Pry off the cover (2) or knock it off (use a screwdriver).



Bild/Fig. 3

Magneto flywheel

Insert adjustable pin spanner, as illustrated, unscrew the collar nut and remove the spring washer.

Slip on the protecting cap and pull the magneto flywheel with puller (1).



Bild/Fig.

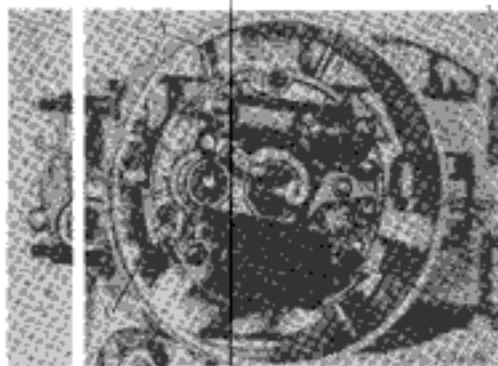

Bild/fig 5

Stator plate

Remove the spark plug connector from the ignition cable. Unscrew 3 cross-head screw (1) with washers, remove the stator plate and the Woodruff key (2).

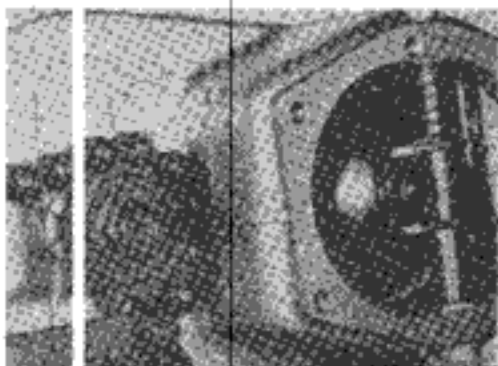

Bild/fig 6

Sprocket

Apply the hook wrench (1) with its chain to the sprocket, as illustrated, unscrew the nut (2) and remove the special washer.



Bild/fig 7

Pull off the sprocket.

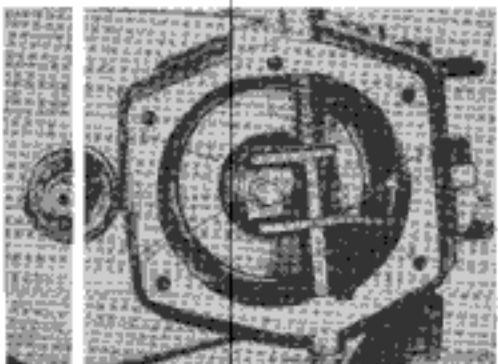

Bild/fig 8

Starting and driving clutch

Unhook the torsion spring (1).

Unscrew the fillister head screw (4) with sealing ring, remove bush (3), clutch lever (2, with control cable) and torsion spring.

Remove thrust cup (5) with thrust pin.

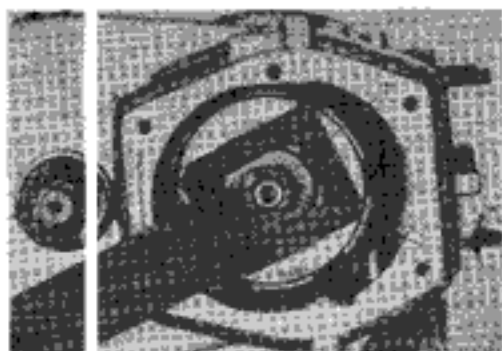

Bild/Fig. 7

Hold the washer (1) with the holding tool, unscrew the nut (2).

Remove the washer (1), shims (6, Fig. 8), inner and outer plates with spring washers.

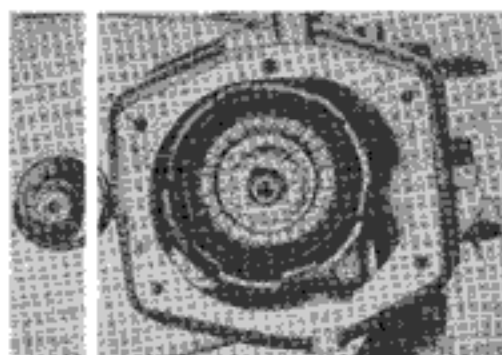

Bild/Fig. 8

Remove the clutch hub (1) (if need be, loosen it by a slight blow).

Remove Woodruff key, if existing (to be omitted during remounting).

Remove the clutch case (2) with centrifugal weight (3), ring (4), clutch plate underneath it and the check plate.

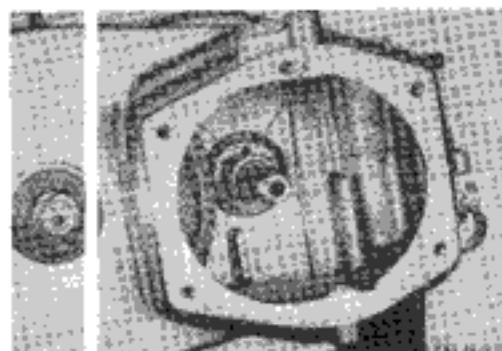

Bild/Fig. 11

Remove bush (1) and check plate (2).

Note:

If the bush sticks; pull it off together with the grooved ball bearing (when exchanging the grooved ball bearings).

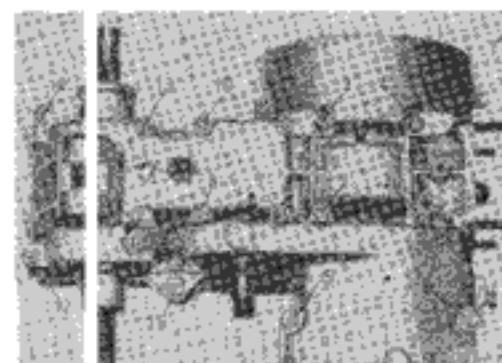

Bild/Fig. 12

Splitting the crankcase

Unscrew 15 fillister head screws and remove the lower part of crankcase.

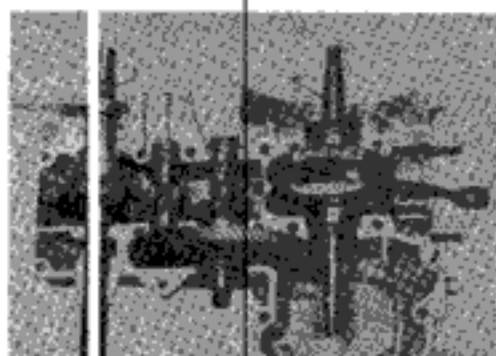

Bild/Fig. 3

Crankshaft and gearbox

Remove pedal shaft (1), gearshaft (2), cover plate (3), mainshaft (4) and crankshaft (5).

Unscrew the crankcase lower part from the mounting jig.

WORKING ON INDIVIDUAL PARTS

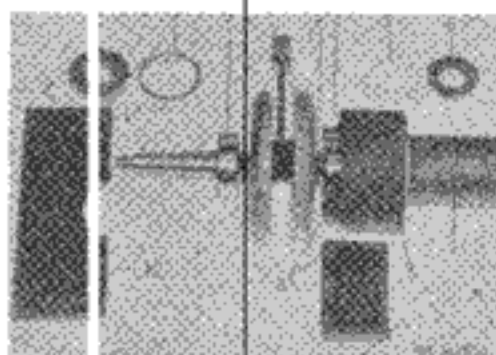

Bild/Fig. 4

Exchange of crankshaft bearings

Pulling the grooved ball bearings

Remove oil seals (1 and 6) and washers (2 and 5). Pull the grooved ball bearings (3) with puller shells (9), puller sleeve (7) and clamping ring (8).

Installation dimensions of crankshaft

The installation dimension of the crankshaft is, measured over both grooved ball bearings, 57.75 mm (2.273 in.).

There is no need to measure the crankcase.

Example:

Fitting dimension of crankshaft:	57.75 mm	2.273"
Dimension of crankshaft, measured over both crank webs:	34.20 mm	1.346"
Width of both grooved ball bearings:	+ 22.00 mm	0.866"
	56.20 mm	- 56.20 mm 2.212"
Difference to be compensated:	1.55 mm	0.061"

The difference of 1.55 mm (0.061 in.) is compensated by shimming washers to be fitted on the crankshaft directly under the inner races of the bearings.

Fit the 0.5 mm (0.020 in.) thick shimming washer on the clutch side and all others on the magneto side.

Pre-assembly of crankshaft

Place the intermediate plate (10) between both crank webs and support it at both ends. The crankshaft must rest freely on it.

Heat the grooved ball bearings and press them home (3).

Fill the grooves of the oil seals with high melting point grease Alvania 3 and lubricate the sealing lips lightly.

Fit the washer (2) of 1.5 mm (0.059 in.) thickness and the oil seal (1) on magneto side crankshaft.

Fit the protective sleeve to the power take-off side crankshaft end and mount the 0.2 mm (0.007 in.) thick washer (5) and the oil seal (6).

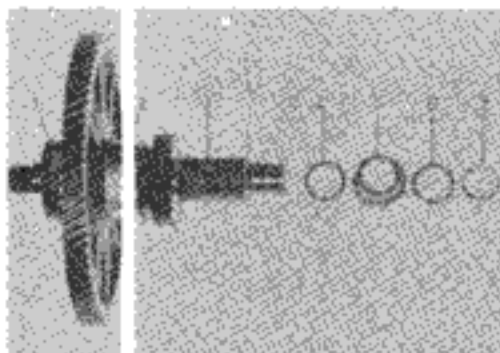

Bild/Fig. 15

Mainshaft with intermediate gear wheels ass'y

Disassembly

Remove oil seal (1), circlip (7), shim (6), sleeve (5) and shim (4).

Note:

The mainshaft (3) with layshaft gears and bearing (2) is available as an assembly only.

Assembly

Fill the groove of the oil seal with high melting point grease Alvania 3 and lubricate the sealing lip slightly.

For protecting the sealing lip of the oil seal, wrap the edges of the mainshaft with scotch tape and slide the oil seal on to a distance of approx. 6 mm (0.236 in.) to the layshaft gear.

Slide the 1 mm (0.039 in.) thick shim (4) and the bush (5, collar to the outside) on the mainshaft.

Fit shims (6) up to the groove for the circlip and insert the circlip (7).

Note:

The bush (5) must not have any axial play, but should still revolve easily.

Gearshaft

The gearshaft is available as an assembly only.

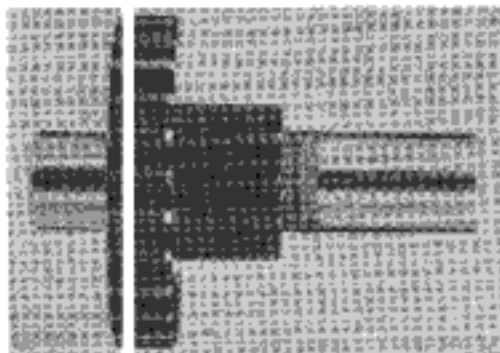

Bild/Fig. 16

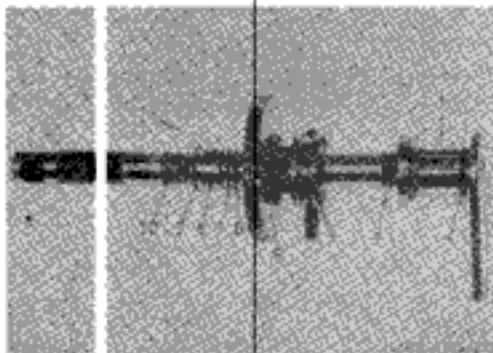

Bild/Fig. 1

Pedal shaft

Disassembly

Remove driving sleeve ass'y (1), driver (4) with brake spring, annular sealing rings (2, 3 and 10), washer (9), 1 mm thick, and sleeve (8).

Remove circlip (7), washer (6), 1 mm thick, and starting wheel (5).

Assembly

Mount the parts in reverse sequence.

Carburettor

The carburettor type and the jet sizes are selected by means of tests in the factory.

Final adjustments, if required, are to be made with the jet needle. Raising the jet needle position produces a richer mixture, lowering it produces a leaner one.

Changing the jet needle position can have an effect on the composition of the fuel mixture only in the lower and medium revolution range.

Upon opening the throttle, the engine should not "cough", nor should the revolutions drop at any throttle position. If the engine splutters or falters or if black fumes are coming out of the intake silencer, the mixture is too rich. Repeated short blow-backs or "sneezing" and starting difficulties denote too lean a fuel mixture.

Wash the carburettor from time to time in petrol, check all parts for wear and replace them, if necessary.

ATTENTION!

WHEN DISASSEMBLING THE MAIN JET ON THE BING CARBURETTORS 85/12/101 AND 85/12/102, THE LOOSE RING IN THE NEEDLE JET MUST NOT BE REMOVED, BECAUSE THE ENGINE FUNCTION WOULD SERIOUSLY BE AFFECTED!

Intake silencer and micronic air filter

Pay attention to versions, see spare parts list

Magneto-generator

Replacing the ignition or generating armature

Remove the defective armatures and replace them by new ones.

Ignition and generating armatures are available as spare parts ready to be fitted and can be mounted to the stator plate without special device. After fitting a new armature, it is absolutely necessary to check the air gap between the armature poles and the flywheel, because the maximum ignition and lighting output is achieved only with the specified air gap of 0.25...0.35 mm (0.0098...0.0138 in.).

A prerequisite for measuring and adjusting is a perfect condition of the crankshaft bearings. The air gap is to be measured at various positions through the recesses in the magneto flywheel. In case of deviations, slight corrections can be made by loosening the armature fitting screws and repositioning the armature. The adjustment can also be made through the recesses in the magneto flywheel.

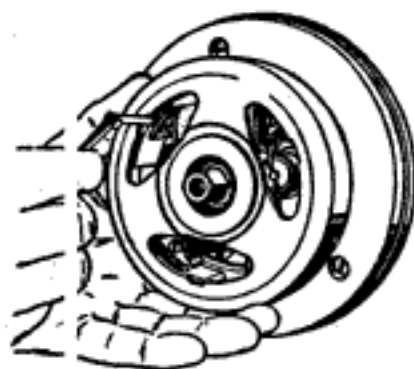

Bild/Fig. 18

Replacing the breaker points

1. Remove the breaker points.
Unscrew pivot pin, if screwed in.

Attention!

Pivot pin is couled.

New breaker points (pivot pin riveted to contact carrier) and new stator plates are manufactured without threads.

Use only the breaker points specified for this engine.

2. Lubricate the lubricating pad before installation with BOSCH grease Ft 1 v 4 and apply the grease wedge to the rub block. Make sure that no oil or grease gets on the breaker points.
3. Insert new breaker points into the through- or thread bore and fasten.
4. Fasten short-circuiting cable.

Replacing the condenser

1. Unsolder both cables.
2. Press the condenser out of the stator plate with a wooden dowel.
3. Scrape the high spots at the bore for the condenser, caused by previous swaging.
4. Fit the new condenser and swage carefully.
5. Resolder both cables.

Decarbonizing the exhaust system and the cylinder

Carbon deposits in the combustion chamber, in the exhaust port of the cylinder and in the exhaust system must be removed at the latest when the engine output drops or if the engine tends to four-stroke in spite of correct carburettor setting.

Usually, cleaning will be required after 3000 ... 4000 km (1900 ... 2500 miles).

Exhaust system

Remove the exhaust system.

Clear the inside of the exhaust pipe by pulling a commercial wire brush through it.

The exhaust silencer should be stripped for cleaning; heat the insert to red-hot and knock or scrape off any remaining deposits. Remove carbon deposit from the tie-bar and in the end piece.

Do not modify or tamper with the inside of the exhaust system. Any such modifications not only adversely effect fuel consumption, engine performance and noise, but are also against regulations and will be prosecuted!

Cylinder

Unscrew the cylinder and remove carbon deposit in the combustion chamber with a screwdriver.

Avoid damages to the combustion chamber surface.

Remove carbon deposit from the exhaust port and in the transfer ports with a screwdriver.

Piston

Carefully remove only large carbon deposits (flakes) from the piston head.

Do not attempt to scrape the piston head bright.

REBUILDING THE ENGINE

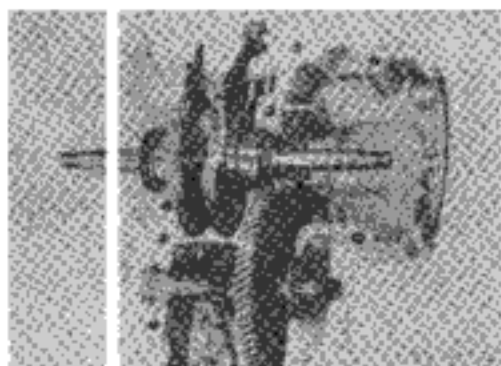

BildFig. 19

Mount the crankcase upper part with 2 hexagon head screws M 8 x 65 and nuts to the mounting jig (see Fig. 2).

Coat the mating surfaces of the crankcase parts with Loctite 572; do not apply sealing compound to the bearings.

Crankshaft and mainshaft

Insert the pre-assembled crankshaft.

Make sure that the washer (1) engages in the groove of the crankcase upper part and that both oil seals be uniformly in contact (to the inside).

Insert the pre-assembled mainshaft; the oil seal (2) must slightly protrude over the outer edge of crankcase.

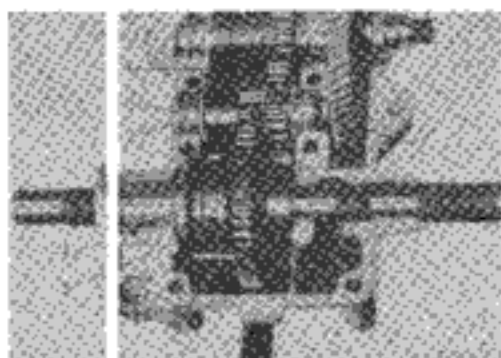

BildFig. 20

Gearshaft and pedal shaft

Insert gearshaft with distance sleeve (1), sleeves (2) and cover plate (5).

Insert pre-assembled pedal shaft, washer (4) must be in contact with the collar of the driver and brake spring (3) must engage between the two paths (see arrow).

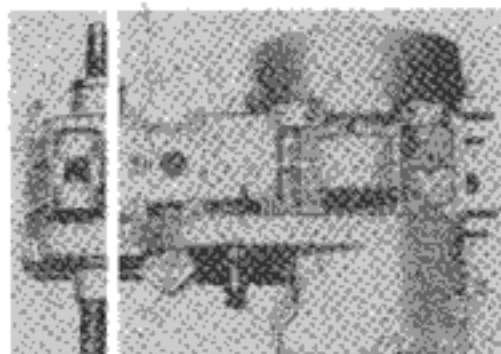

BildFig. 21

Put on the lower part of crankcase and fit the oil seal (2, Fig. 19) flush with the outer edge of crankcase.

Screw the parts of the crankcase together with 10 fillister head screws (1...4, 7...11 and 13) M 6 x 70, 4 fillister head screws (5, 6, 12 and 14) M 6 x 55 and 1 fillister head screw (15) M 6 x 22.

Attention!

Tighten the fillister head screws in the sequence depicted from 1...15.

Tightening torque 10...12 Nm (1...1.2 kpm).



Bild/Fig. 22

Stator plate

Insert woodruff key (2).

Pass the ignition-, lighting- and short-circuiting cable through the rubber grommets, fit the stator plate, taking care of the marking lines (3). New stator plates do not have marking lines and shall be fastened in the center of their fitting slots.

Coat 2 cross head screws (1) M 4 x 14 and washers with "Diamant" sealant and tighten them.

Tightening torque 3 ... 4 Nm (0.3 ... 0.4 kpm).

Fasten spark plug socket on the ignition cable.

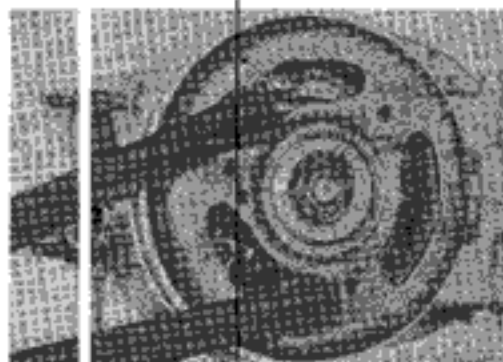

Bild/Fig. 23

Magneto flywheel

Remove any traces of grease from the tapers of crankshaft and magneto flywheel (Tri or petrol).

Fit the magneto flywheel, pay attention to woodruff key, insert the spring washer and fasten it with the collar nut (1) M 10 x 1. Use adjustable pin spanner.

Tightening torque 37 ... 40 Nm (3.7 ... 4 kpm).

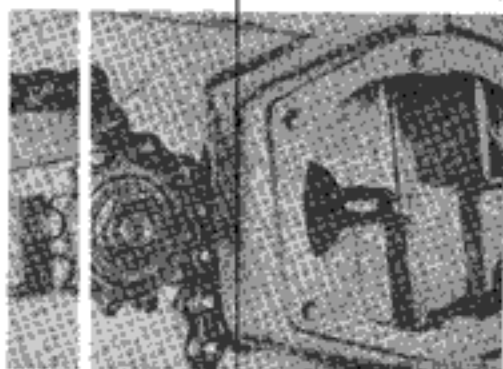

Bild/Fig. 24

Sprocket

Fit the sprocket (ground face showing downwards), put on the special washer and fasten with nut M 12 x 1.

Use hook wrench (1) with chain, as illustrated.

Tightening torque 50 ... 60 Nm (5 ... 6 kpm).

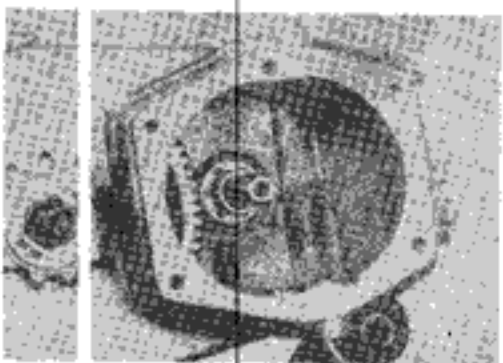

Bild/Fig. 25

Centrifugal clutch

(Starting and driving clutch)

Put on the thrust washer (2), its chamfer pointing to the crank web.

Fit the sleeve (1) completely into its seat, if necessary by tapping it slightly.

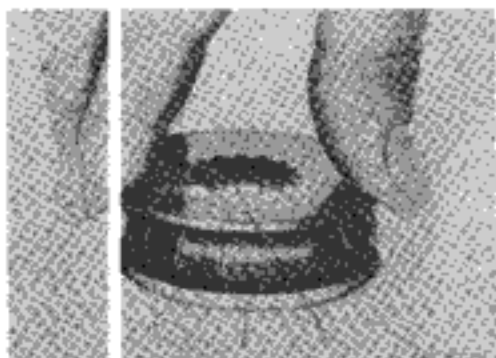

Bild/Fig. 26

In order to avoid a wrong adjustment of the axial play of the clutch plates, the flyweight must rest flatly on the plates when installing it.

Tap the flyweight (1) slightly on a flat surface, put it into the clutch plate (2), align it by pressing and turning the inner clutch plate (3).

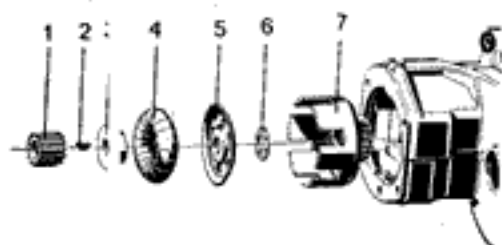

Bild/Fig. 27

Fit the clutch case (7) and put on the thrust washer (6, chamfered side showing downwards).

Mount the clutch plate (5), insert the flyweight (4), fit the ring (3) and mount the clutch hub (1).

Note:

Woodruff key (2) is omitted (also when nut is existing).

New manufacture of the crank pins and clutch hubs is carried out without nut.

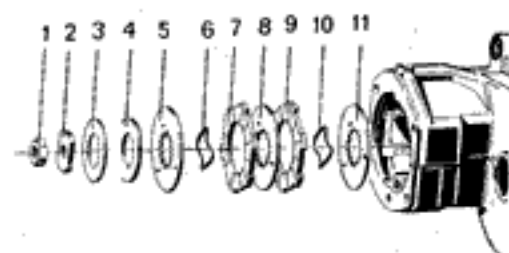

Bild/Fig. 2

On SACHS 505/1 A, 505/1 A NL and 505/1 C engines, insert inner plate (11) 1.7 mm thick, outer plate (9), spring washer (10), inner plate (8), 2.5 mm thick, outer plate (7), spring washer (6) and inner plate (5) 2.5 mm thick.

Fit shimming washers (3 and 4) as required, insert washer (2) and screw on nut (1), see axial play.

On SACHS 505/1 B engine, insert inner plate (11) 1.7 mm thick, outer plate (9), spring washer (10), inner plate (8) 1.7 mm thick, outer plate (7), spring washer (6) and inner plate (5) 1.7 mm thick.

Fit shimming washer (4) 1.7 mm thick and shimming washer (3) as required, insert washer (2) and screw on nut (1), see axial play.

Check the axial play between shimming washers (3 and 4) and washer (2) and fit as many shimming washers as are necessary for achieving an axial play of 0.4 ... 0.6 mm (0.016 ... 0.024 in.).

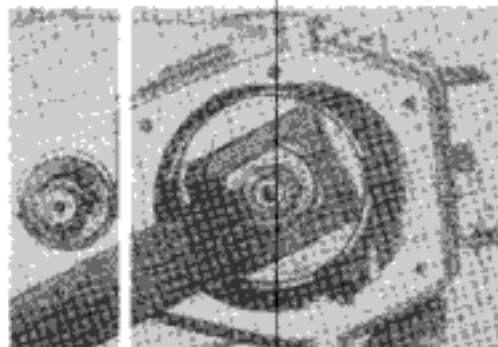

Bild/Fig. 29

Remove any traces of grease from the threads of crank pin and nut (Tri or petrol), coat them with Loctite AAV, screw on the nut, hold the washer (1) with holding tool (3) and fasten the nut.

Tightening torque 35 ... 40 Nm (3.5 ... 4 kpm = 25.3 ... 28.9 ft lb).

Note:

When turning the chain sprocket, the clutch case must rotate freely.

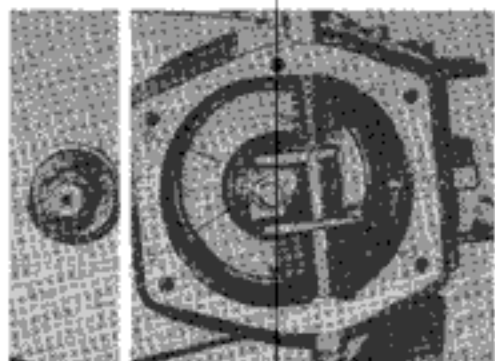

Bild/Fig. 30

Mount thrust cup (5) with thrust pin.

Hook the control cable for the starting clutch to the clutch lever (2) and pass it through the bore in the housing.

Insert fillister head screw (4) M 8 x 1 x 100 with sealing ring, fitting at the same time the sleeve (3), clutch lever and the torsion spring (1), fasten the fillister head screw and hook the torsion spring on the housing.

For adjusting the clutch lever, see Fig. 38.

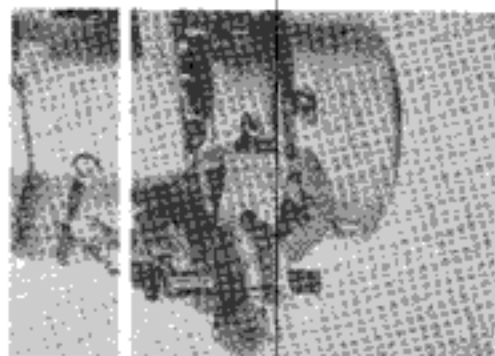

Bild/Fig. 31

Needle cage and piston

Put on the cylinder flange gasket, its graphitized side towards the crankcase.

Insert the oiled needle cage in the connecting rod eye.

Place the piston with locating pin (arrow pointing to the exhaust) onto the connecting rod.

Place the piston on self-made wooden fork (1), insert the gudgeon pin, if necessary, pull it home with the gudgeon pin puller and insert bush.

Fit both wire circlips.

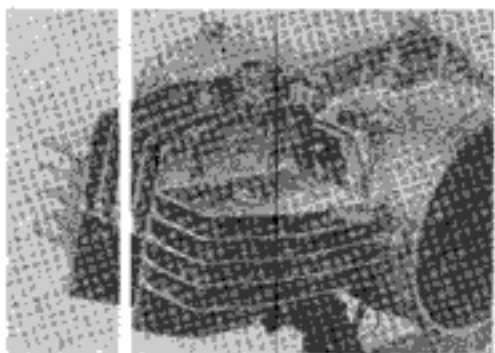

Bild/Fig. 32

Cylinder

Mount the cylinder, slightly oiled (exhaust pipe showing to the lower part of crankcase), (remove wooden fork) and fasten it with 4 nuts M 6 and washers diagonally.

Tightening torque 8 ... 10 Nm (0.8 ... 1 kpm) = 5.7 ... 7.2 ft lb).



Bild/Fig. 33

Ignition timing

It is recommended to check the ignition timing each time the engine is serviced, because the engine performance depends on it.

Also check the spark plug gap (0.5 mm = 0.020 in.).

Spark advance: 2.5 ... 3 mm before TDC
(0.098 ... 0.118 in.)

Breaker points gap: 0.4 ± 0.05 mm

Measuring instruments: Spark advance timing gauge,
Feeler gauge
0.4 mm

Attention!

For a spark advance of 2.5 ... 3.0 mm (0.098 ... 0.118 in.) before TDC, it is necessary, owing to the inclination angle of 45° (spark plug bore in relation to the piston stroke) to set the F & S spark advance timing gauge at 3.5 ... 4.2 mm (0.138 ... 0.165 in.).

On the magneto flywheel and on the housing, marks have been punched.

"O" coincides with the chisel mark on the housing if the piston is at top dead center.

"M" coincides with the chisel mark on the housing in the firing position.

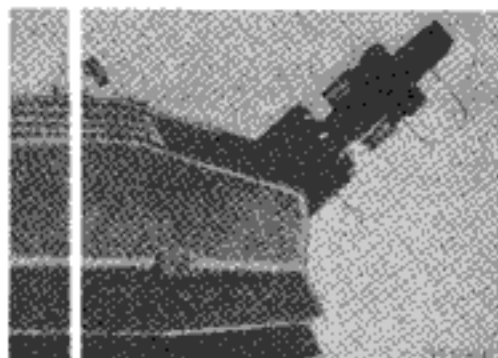

Bild/Fig. 34

Measuring and establishing ignition markings

If there are no ignition markings, the top dead center and the firing position must be determined anew with the spark advance timing gauge and marked.

Example:

1. Place piston at top dead center, using the spark advance timing gauge.
2. Punch the chisel mark on the crankcase (Fig. 33) or the „O“ mark on the magneto flywheel (Fig. 33).
3. Screw the adjusting nut [2, Fig. 34] until it slightly touches the bush [3, Fig. 34] and turn this nut back by the amount of the spark advance.

One whole turn of the adjusting nut corresponds to 1 mm (0.039"). The marks on the adjusting nut (– 0.25 mm = 0.0098") and on the guide bush (0.1 mm = 0.039") allow to set the spark advance correctly.

4. Turn the magneto flywheel against the direction of rotation until the adjusting nut touches the bush (the piston must be in contact with the adjusting bolt [1, Fig. 34]).
5. Punch the "M" marking to the magneto flywheel.

Adjustment procedure for ignition setting:

1. Set the breaker points gap at maximum lift of cam at 0.4 ± 0.05 mm.
2. Turn the magneto flywheel so far until the "M" marking on the flywheel coincides with the chisel mark on the crankcase.
3. Turn the magneto flywheel slightly in the direction of rotation; now, the breaker points must start opening. If not, adjust the ignition point by turning the stator plate in its slots.

Turning the stator plate against the direction of rotation of the magneto flywheel advances the ignition, turning it in the direction retards the ignition.

4. After each adjustment, fasten the stator plate fitting screws.

Cover

Mount the cover (2, Fig. 3) with light rubber mallet blows.

Remove the engine from the mounting jig.



Bild 7 g. 35

Intake pipe, carburettor and intake silencer

Fit the gasket or gasket, intermediate flange and gasket and fasten the intake pipe (5).

Mount the carburettor and fasten it.

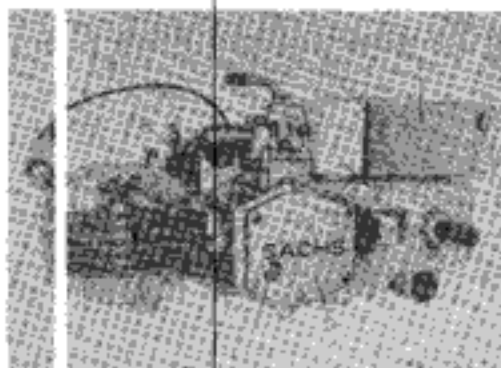
Put round sealing ring on the carburettor side of intake silencer housing (2), insert the plate into the housing and fasten it with 3 resp. 2 fillister head screws M 5 x 10 to the carburettor.

Fit pressure spring and choke slide over the control cable and insert it in the intake silencer housing.

Fit micronic air filter with filter housing into the intake silencer cap (1) and fasten it to the intake silencer housing with a clip.

Fill in the gearbox oil

Fill into the clutch housing 250 cc special SACHS gear oil (F & S part No. 0263 014 002) or other oils, see oil level check, page 32.

Coat only the mating surface of the clutch housing with sealing compound No. 40, put on the gasket and fasten the cover plate (3, Fig. 35) with 5 lens head screws M 5 x 14.

Fitting and lubricating the control cables

Before mounting the engine into the frame, check the control cables, control levers and twist grips and replace damaged parts.

Control cables should be greased or oiled before fitting. Make sure that the control cables run in large curves and are not jammed. Control cables and control levers must always operate smoothly.

The diameter of the inner control wire should be 1.6 mm (0.063 in.), the inner diameter of the outer casing 2.5 mm (0.098 in.).

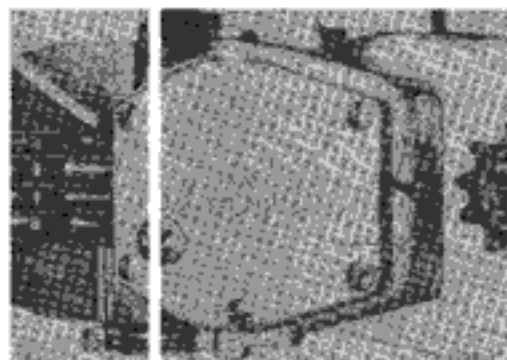

Bild/fig. 36

Installing the engine into the frame

Before fitting a new or a replacement engine, pull the sealing cord (1) out of the air vent bore of the cover (2), since there will otherwise not be any air-venting of the gearbox.

Install the engine in the frame and fasten it.

Chain

Fit the chain to the rear wheel and join it with the link. The closed end of the clamping spring of the chain link points in the running direction. Take care of correct chain tension; chain sag approx. 3 cm (1.2 in.).

Control cables

Fit the control cables for throttle and starter choke. For the control cable for starting and decompressor lever, see Fig. 37 and 38.

Electric connections

Slide an insulating hose over the wires coming out of the engine and connect them at the terminal block (see instructions for magneto-generator on page 30).

Exhaust system

Tighten at first the cleaned exhaust system to the cylinder and tighten to the frame, in order to prevent stress within the system. Connect fuel line to the carburettor.

Brake linkage

Fasten brake linkage in brake lever on engine.



Bild Fig. 37



Bild Fig. 38

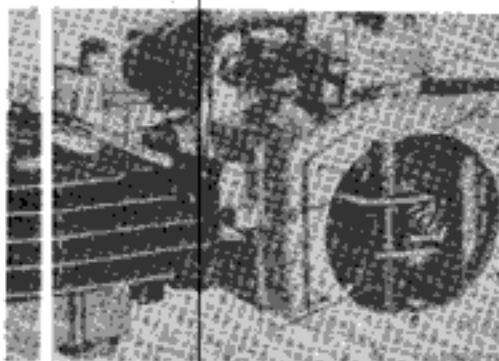

Bild Fig. 39

Removing and connecting the starter clutch control cable in the engine

Removing

Loosen the control wire at the starter lever (handle bars). Unscrew the cover.

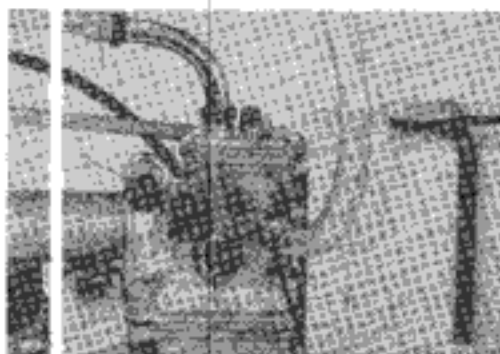
Unhook the torsion spring (7), unscrew the fillister head screw (4) with sealing ring, remove bush (5), clutch lever (6, with control wire) and torsion spring.

Connecting

Hook the new control wire at the clutch lever, insert it through the bore in the housing and mount the parts in the reverse order.

Fit the outer casing (2) with rubber cap (3), insert the control wire through the decompressor (1) and fit outer casing. Pass the control wire through the starter lever.

Adjusting the starter and decompressor lever

Screw the adjusting screw (1) up to the slightly perceptible stop at the pressure pin (3), then turn it back by $\frac{1}{4}$ turn, so that there is a slight play between the pressure pin and the adjusting screw. Lock the adjusting screw with nut (2).

Adjust the reach of screw of the adjusting screw at the starter lever (at the handle bars).

Pull the control wire out up to the stop and fasten it. Adjust the adjusting screw so that the starter lever has 1 ... 2 mm (0.04 ... 0.08 in.) play.

Lock the adjusting screw.

On starter levers without adjusting screw, pull the control wire out up to the stop and push it back until there is a play of 1 ... 2 mm (0.04 ... 0.08 in.) for the outer casing between the decompressor and the starter lever, then clamp the control wire fast.

Note:

If the starter clutch slips during the starting procedure, check the axial play of the clutch plates (see Fig. 28) and adjust it again.

Test run

Adjusting the carburettor

Adjust the carburettor while the engine is warm. In order to ensure that during normal operation the choke is out of operation, the control wire for the choke must have a play of 1 ... 2 mm (0.04 ... 0.08 in.).

Unscrew the throttle stop screw (3) and adjust the control wire so that the throttle is completely closed. Screw the throttle slide stop screw so that the engine, under operating temperature and with throttle twist grip closed, runs perfectly smooth.

Adjust the adjusting screw (1) so that the control wire between the carburettor and the throttle twist grip has a play of 1 ... 2 mm (0.04 ... 0.08 in.).

Note:

The above adjustment must be accomplished with utmost care, because the centrifugal clutch will engage if the engine idles too fast.

Tightening torsion for all nuts and bolts on entire bike.

Name	Unit: kg - m (ft - lb)
Front Wheel Nut	3.0 - 4.0 (21.7 - 29)
Rear Wheel Nut	4.0 - 5.0 (29 - 36)
Engine & Frame Mount Bolt	1.8 - 2.5 (13 - 28)
Rear Cushion Nut	3.0 - 4.0 (21.7 - 29)
Muffler Exhaust pipe	0.8 - 1.2 (5.8 - 8.7)
Muffler Mount Bolt	1.8 - 2.5 (13 - 18)
Head Light Rim Bolt 4 ^{mm}	0.3 - 0.4 (2.2 - 2.9)
Crank Arm Nut	0.8 - 1.2 (5.8 - 8.7)
Speedometer Cable Bolt 4 ^{mm}	0.3 - 0.4 (2.2 - 2.9)
Rear Fork Pivot Bolt	0.3 - 4.0 (21.7 - 29)
Seat Mount Bolt	2.0 - 3.0 (14.5 - 21.7)
Seat Adjuster Bolt	3.0 - 4.0 (21.7 - 29)
Handle Mount Bolt	1.8 - 2.3 (13 - 16)

Standard Accessories:

Hexagonal Head Bolt	6 ^{mm}	0.8-1.2 (5.8 - 8.7)
Cross-recessed Head Screw	6 ^{mm}	0.8-1.2 (5.8 - 8.7)
Bolt	6 ^{mm}	0.8-1.2 (5.8 - 8.7)
Cross-recessed Head Screw	5 ^{mm}	0.3-0.4 (2.2 - 2.9)

Bike Assembly Instruction

1. Open carton of bike.
2. Take front wheel out of the carton.
3. Carefully remove the complete bike including handle bar from carton and put it on the fixing stand. Keep it upright.
4. Remove all packed parts: front brake panel, turn signal, rear view mirror, pedals, reflector and reflector gasket.
5. Put handle bar on top crown of front fork and tighten them with 4 hexagon head bolts. Also fasten turn signal switch and engine stop switch at their position.
6. Install front fender on bottom crown of front fork and tighten them with six pieces of hexagon head bolt.
7. Remove front wheel axle which below front fork. Put front wheel brake panel, right & left spacers altogether in the mounting hole on front fork and then tighten them.
8. Wire speedometer cable, front brake cable, clutch cable and choke cable to proper position.
9. Dismount head light case. Mount front turn signal right and left each beside head light case. Replace head light case after the terminals are connected.
10. Mount rear turn signals at both sides of rear bike. Connect electric wire terminals, too.
11. Mount rear view mirror on lever bracket R/H and fix it after being adjusted to a proper height.
12. Mount reflectors along with gasket on both sides of front fork.
13. Clean the entire bike.

Engine Starting & Preparation Instructions for Riding

1. Remove right chain cover and dismount battery.
2. Remove battery fluid plug. Fill battery with electrolytic fluid of sulphuric acid of specific gravity 1.26(20°C) and charge it under general way.
3. Replace the battery to the bike when charge is finished. Then properly connect the wire terminals.
4. Replace right chain cover and tighten it with screws.
5. Make sure fuel cock is certainly connected with the oil pipe of carburetor and put fuel cock switch at "ON" position.
6. Remove fuel tank cap and fill it with gasoline and synthetic oil of mixture ratio of 50 to 1.
7. Turn key switch to "NO" position. (Under bottom crown of front fork)
8. Remove engine stop switch to "RUN". (Beside right grip)
9. Remove head light and tail light switch to "OFF". (Beside left grip)
10. To test and make sure turn signals work well. (Brightness)
11. To check if the free play of front and rear brake is proper and brake light is bright enough.
12. Hold clutch lever tightly with left hand and pedal by left foot. Give the throttle grip a slight inside turning with right hand at the same time of pedalling. Engine then started. Replace clutch.
13. If engine itself is cool, choke lever should be grasped together with clutch lever so that fuel mixture increasing for which is helpful for easy starting. Replace choke lever when engine is warmed up.

Adjustment for Drive Chain

The tension which chain gets is correct when chain itself has 1-2cm slack at the central point between two sprockets.

Adjusting process: to loosen rear wheel axle nut. Turn adjuster nut until both testing mark and socket on adjuster get into a line.

Brakes Adjusting

The free play at the end of front brake lever should be 2-3cm.

Inspect front and rear brake every time before you drive the bike. Adjust adjuster bolt and nut, if necessary.

Check Spark Plug

Check spark plug and if necessary clean carbon & contamination around cap and electrodes area with spark plug cleaner.

Spark gap is normally 0.5mm-0.6mm.

If insulator is broken, replace a new one.

Drive Chain Lubrication

The lubrication of drive chain will be done depends on fact.

Maintenance of Battery

1. To check the level of battery electrolytic fluid often. Fill with distilled water until it reach the HIGHEST level if you find battery fluid down below the LOWEST level.
2. Using a gravimeter to test the specific gravity of battery fluid. If its specific gravity is less than 1.20 (20°C), the battery should be charged.
3. If the bike will be stored for a long time, it's suitable to dismount the battery from the bike and charge once a month.
4. When the bottom gap of electric channel built up with white deposits that indicating the battery will to be of no use.

Battery Charge

1. Charging efficiency: 0.4AH
2. Charge until the below items are proper.
 - a) Specific gravity: 1.26-1.28 (20°C)
 - b) Voltage: 7V-8V
3. Charging time: 10-12 hours

By referring the following time table, please have your bike a periodic inspection and lubrication so that it can be operated under better condition.

Item	Time	Month of Riding				
		1st	3rd	6th	12th	18th
Clean or adjust spark plug			x	x	x	x
Ignition timing adjust				x	x	x
Clean air cleaner				x	x	x
Adjust and clean carburetor				x	x	x
Clean oil filter				x	x	x
Chain adjusting & lubrication		x	x	x	x	x
Adjust front & rear brake		x		x	x	x
Inspect front & rear brake shoe				x	x	x
Check & adjust bearing ball of handle				x	x	x
Electrolytic fluid check		x	x	x	x	x

After first 18 months riding, you may do the above maintenance every six months.

Troubleshooting

Item	Possible Cause	Remedy
<p>Difficult or no starting</p>	<p>1. Spark plug or ignition system</p> <ul style="list-style-type: none"> a) Dirty spark plug b) Wet spark plug c) Poor terminal contact d) Dirty breaker points e) Incorrect point gap f) Incorrect ignition timing g) Faulty ignition coil h) Condenser short circuit <p>2. No fuel delivery</p> <ul style="list-style-type: none"> a) Fuel tank vent is clogged b) Fuel cock encumbered c) Fuel pipe clogged with dirt 	<p>Clean</p> <p>Clean</p> <p>Adjust</p> <p>Clean</p> <p>Adjust</p> <p>Adjust</p> <p>Replace</p> <p>Replace</p> <p>Clean</p> <p>Clean</p> <p>Clean</p>
<p>Engine sudden stop during driving</p>	<ul style="list-style-type: none"> 1. Dirty spark plug 2. Dirty breaker points 3. Fuel pipe is clogged 4. Clogged carburetor fuel jets 	<p>Clean</p> <p>Clean</p> <p>Clean</p> <p>Clean</p>
<p>Hard steering</p>	<ul style="list-style-type: none"> 1. Worn or bad steering ball bearing 2. Steering ball race too tightened 3. Low tire pressure 	<p>Replace</p> <p>Adjust to standard tension</p> <p>Pump air to required</p>

Item	Possible Cause	Remedy
Brakes do not hold	1. Brake shoe worn out 2. Brake arm serration flattened 3. Brake cam worn out	Replace Replace Replace
Turn signal out of order	1. Turn signal switch a) Poor contact of flasher relay b) Flasher relay short circuit c) Incorrect wire connection d) Bad ground return for turn signal itself. e) Battery fuse blown out 2. Bulb a) Filament blown out b) Incorrect voltage	Replace Replace Correct Repair Reset Replace Replace
Horn can't work	1. Horn diaphragm worn 2. Bad ground return of horn button 3. Poor contact of wire 4. Incorrect adjustment 5. Battery fuse blown out	Replace Repair Adjust Correct Reset
Head or tail light out of order	1. Bulb tungsten filament blown out 2. Poor contact of switch	Reset Repair
Brake light out of order	1. Filament blown out 2. Brake switch out of order 3. Battery fuse blown out 4. Poor contact of wire	Reset Replace Replace Adjust

Electrical Wiring

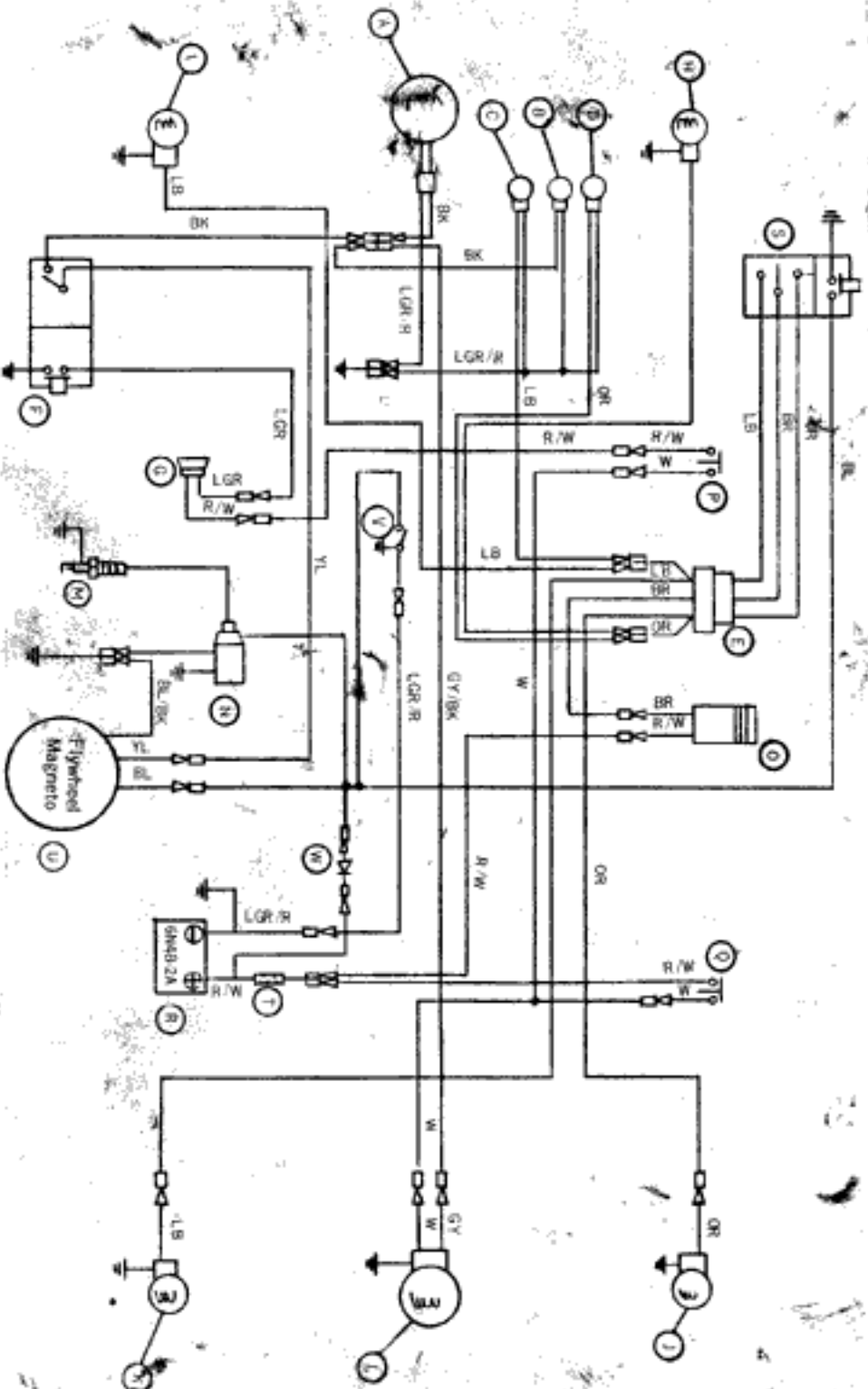

COMPONENT	WIRE COLOR	WIRE GAUGE
NEIGH LAMP/V1.5W	OR	16
FLASHER LAMP-R-V1.5W	OR	16
FLASHER LAMP-L-V1.5W	OR	16
SOLENOID CONNECTOR	OR	16
HORN S.W. L/H	OR	16
HORN	OR	16
FRONT TURN SIGNAL-W	OR	16
FRONT TURN SIGNAL-R	OR	16
HEAD TURN SIGNAL	OR	16
REAR TURN SIGNAL	OR	16
TAIL LIGHTS/V1.5W	OR	16
TAIL LIGHTS/V1.5W	OR	16
SOLENOID P/B	OR	16
LOCK	OR	16
SIGNAL RECTIFIER	OR	16
FLASHER RELAY	OR	16
FRONT STOP S.W.	OR	16

WIRE COLOR	WIRE GAUGE
RED	16
ORANGE	16
RED/WHITE	16
YELLOW	16
BLACK	16
LIGHT GREEN/RED	16
BLACK	16
BROWN	16